



Macintosh™ MacTerminal™

Lets your Macintosh computer communicate with mainframes, information services, and other personal computers.

The screenshot shows the MacTerminal application window with a menu open over the 'Edit' menu item. The menu options are: Undo, Cut, Copy, Copy Table, Paste, Clear, Select All, and Show Clipboard. A mouse cursor is pointing at 'Copy Table'. The main window displays a table titled '3278 - Division Sales' with columns for 'PROJECTED' and 'ACTUAL' sales figures across various regions. A hand is holding a mouse connected to the Macintosh computer.

REGION		PROJECTED	ACTUAL
Northeast		15,235,000,000	22,347,489,260
North Cent		10,520,000,000	12,562,873,342
Northwest		11,875,000,000	20,567,893,734
Southeast	Wells, GA	13,500,000,000	15,674,876,230
South Central	Friedman, TX	10,567,000,000	14,675,687,300
Southwest	Romano	45,750,000,000	52,132,463,675

Copyright

This manual and the software described in it are copyrighted with all rights reserved. Under the copyright laws, this manual or the software may not be copied, in whole or in part, without written consent of Apple, except in the normal use of the software or to make a backup copy of the software. The same proprietary and copyright notices must be affixed to any permitted copies as were affixed to the original. This exception does not allow copies to be made for others, whether or not sold, but all of the material purchased (with all backup copies) may be sold, given, or loaned to another person. Under the law, copying includes translating into another language or format.

You may use the software on any computer owned by you, but extra copies cannot be made for this purpose.

©1985, 1986 Apple Computer, Inc.
20525 Mariani Ave.
Cupertino, CA 95014
(408) 996-1010

Apple, the Apple logo, MacTerminal, and Lisa are trademarks of Apple Computer, Inc.

Macintosh is a trademark of McIntosh Laboratory, Inc., and is being used with express permission of its owner.

Auto Link 212A is a trademark of U.S. Robotics Inc. CompuServe is a registered trademark of CompuServe Corp. DEC, VT52, and VT100 are trademarks of Digital Equipment Corporation. Dow Jones News/Retrieval is a registered trademark of Dow Jones & Company, Inc. DIALOG is a registered trademark of DIALOG Information Services, Inc. IBM is a registered trademark of International Business Machines. MCI Mail is a service mark of MCI Communications Corporation. Excel, Microsoft, and Multiplan are registered trademarks of Microsoft Corporation. Smartmodem 1200 is a trademark of Hayes Microcomputer Products, Inc. Telenet is a registered trademark of GTE. THE SOURCE is a service mark of Source Telecomputing Corp., a subsidiary of Reader's Digest Association, Inc. Tymnet is a registered trademark of Tymshare, Inc., a division of McDonnell Douglas Corporation. Western Union Easylink is a service mark of Western Union.

Simultaneously published in the USA and Canada.

MacTerminal™



Contents

iv	About MacTerminal
v	About This Manual
1	Chapter 1: About MacTerminal
2	Contents
3	What MacTerminal Does
5	The Equipment You Need
6	Getting Started
9	Setting Up a MacTerminal Document
18	Making the Connection
21	A Communications Session
27	Chapter 2: Using MacTerminal
28	Contents
29	Introduction
30	Setting Up a New MacTerminal Document
32	Starting a Communications Session
34	Sending a File
36	Sending a Small Amount of Text
38	Communicating With Another Macintosh
40	Communicating With Another Personal Computer
42	Copying Data From MacTerminal to Another Document
44	Printing
45	Opening MacTerminal Documents
46	Saving a Document
47	Copying a Document or Application From One Disk to Another

49	Chapter 3: MacTerminal Reference
50	Contents
52	MacTerminal Commands
86	Using a Full-Screen Application
87	More About Modems
88	Using MacTerminal With a Hard Disk
89	Troubleshooting
95	Appendix A: Keyboard Layouts
100	Appendix B: Attaching a Modem to the Printer Port With AppleTalk
101	Appendix C: Installing the AppleLine
115	Appendix D: Installing the Apple Cluster Controller
119	Appendix E: MacTerminal as a DEC VT100
120	Appendix F: ASCII Control Characters
121	Appendix G: Pin Assignments for the Apple Modem Data Cable
122	Glossary
137	Index

About MacTerminal

MacTerminal™ is an application that lets your Apple® Macintosh™ computer communicate with other computers. The computers may be directly linked by a special cable, or remotely linked by some kind of transmission facility, most likely telephone lines.

MacTerminal works on a Macintosh Plus, Macintosh, or Macintosh XL. If you have a Lisa 2/5 or 2/10, you need to upgrade to Macintosh XL by using MacWorks XL. See your authorized Apple dealer.

With MacTerminal and the right equipment, you can send a table of figures to a coworker who has a Macintosh, Macintosh Plus, or Macintosh XL (or almost any other personal computer); to a client by way of an electronic mail service, like MCI MailSM, or a telex service, like Western Union EasylinkSM; or to your company's mainframe computer half a continent away. You can get stock quotes and news from a service like Dow Jones News/Retrieval®. Or you can gain access to whole libraries of information through various commercial data bases, such as CompuServe®, THE SOURCESM, and DIALOG®.

About This Manual

To use this manual, you need to know basic Macintosh techniques and operations. Before reading any further, if you have doubts about what **windows** are, what **select** means, or how you **drag** and **click** with the mouse, read *Macintosh*, your owner's guide. It also helps to be familiar with at least one other Macintosh application, such as MacWrite.

Depending on how much you have used the Macintosh and other data communications software, you may want to start in different places in this manual.

- If you have had little or no experience with data communications, turn to Chapter 1, "About MacTerminal," for an explanation of how MacTerminal helps you set up, carry out, and close a communication session with another computer.
- If you're familiar with communications software, and you want step-by-step instructions for most of the tasks you'll do with MacTerminal, turn to Chapter 2, "Using MacTerminal."
- If you want detailed descriptions of each MacTerminal command, turn to Chapter 3, "MacTerminal Reference."
- If you want information about the way the Macintosh keyboard works with MacTerminal, turn to Appendix A, "Keyboard Layouts."
- If you are going to be communicating with an IBM® mainframe, turn to Appendix C, "Installing the AppleLine," or Appendix D, "Installing the Apple Cluster Controller."
- For definitions of key terms, please see the Glossary.





Chapter 1

About
MacTerminal

Contents

3	What MacTerminal Does
3	The Terminal
3	The Other Computer
4	The Connection
5	The Equipment You Need
5	About Modems
5	About Direct Connection
6	Getting Started
6	The Flow of Work
7	What's a MacTerminal Document?
9	Setting Up a MacTerminal Document
10	Setting Up Compatibility
11	Setting Up Terminal Features
13	Preparing to Transmit a File
16	Entering the Access Number
17	Saving the Settings in a MacTerminal Document
18	Making the Connection
18	Receiving a Call From Another Personal Computer
18	Logging On
20	The Macintosh Keyboard
21	A Communications Session
21	Saving Data for Later Use
24	Sending Data to Another Computer
24	Using Another Computer's Applications
25	Terminating a Session

What MacTerminal Does

With MacTerminal, your Macintosh can communicate with

- another Macintosh using MacTerminal
- a Macintosh XL using MacTerminal with MacWorks XL
- any personal computer with appropriate communications software
- an IBM or other mainframe computer

The Terminal

A **computer terminal's** basic job is to send information to and receive information from another computer. A terminal has a keyboard you use to enter information and a display screen to show what you're receiving and sending.

MacTerminal is an application that gives your Macintosh the characteristics of a terminal while your Macintosh retains its power as a computer. With Macintosh as a terminal, you can exchange information with other Macintoshes or other personal computers, as well as gain access to the data bases, applications, and storage capacity of large computers.

MacTerminal is technically called a **terminal emulator** because it can emulate (or imitate) any of three popular computer terminals—a DEC™ VT100™, a TTY (Teletype), or an IBM 3278.

The Other Computer

The computer you want to communicate with must have its own communications software. Each personal computer must have a terminal emulator. A larger computer—for instance, a mainframe—usually has sophisticated data communications software to manage the flow of information between it and many terminals. Larger systems like this are called **host computers**.

For two computers to communicate, they must “speak the same language” at the same speed. MacTerminal has settings that allow you to match the settings of the other computer so that both computers can talk to each other. For example, when you subscribe to Dow Jones News/Retrieval, you receive a manual that describes how to set up your terminal emulator to communicate with the Dow Jones News/Retrieval computer system. These settings are called **communications parameters**.

The Connection

To communicate with another computer, the Macintosh must connect to it, either directly by special cable or indirectly through transmission channels such as telephone lines. If you connect to the other computer by telephone, you'll attach your Macintosh to a device called a **modem**. The modem sends data from MacTerminal over telephone lines to a modem at the other end, which in turn sends the data on to the other computer.

When your Macintosh is directly attached to an IBM or IBM-compatible mainframe and you want your Macintosh to emulate an IBM 3278 terminal, the Apple Cluster Controller or the AppleLine acts as an intermediary.

When MacTerminal makes contact with another computer, you're starting a **communications session**. The session lasts until you terminate the connection. The elapsed time between contact and termination is called **connect time** and is usually what you're billed for when you're communicating with a larger system.

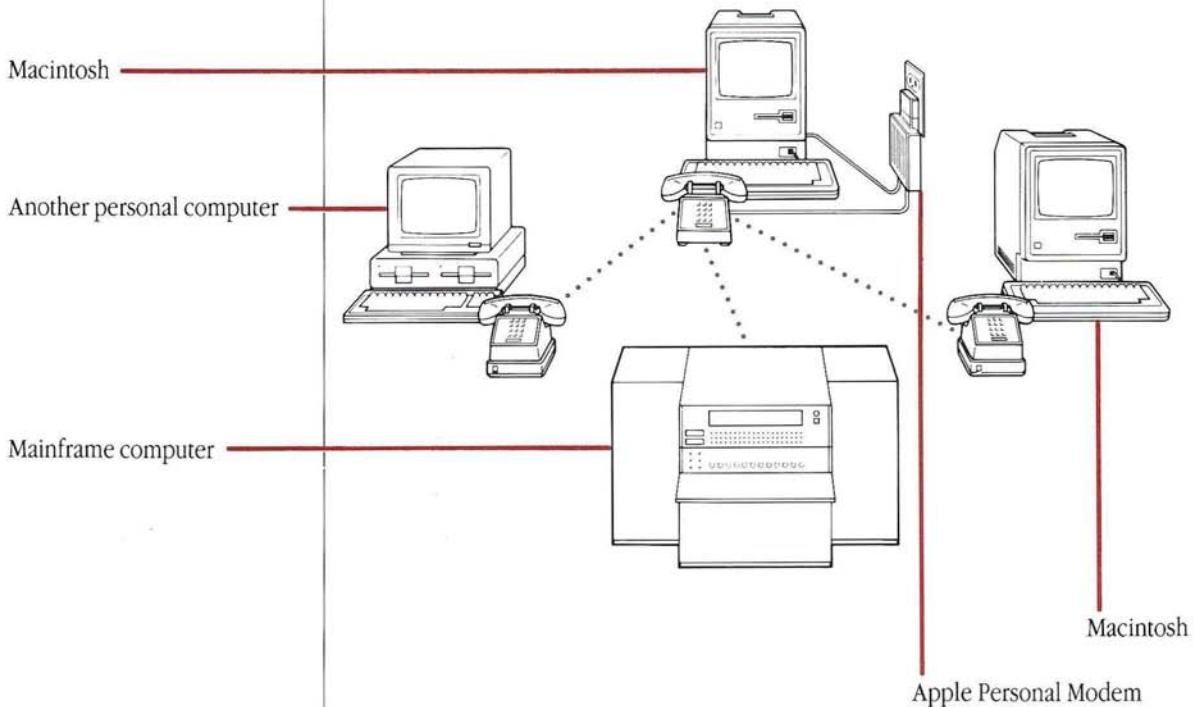

The Equipment You Need

You need the following equipment to use MacTerminal:

- A Macintosh, Macintosh Plus, or Macintosh XL with MacWorks.
- A modem or a direct tie line.
- The AppleLine or Apple Cluster Controller device, if MacTerminal is to emulate an IBM 3278. AppleLine installation instructions are in Appendix C. Apple Cluster Controller installation instructions are in Appendix D.

About Modems

MacTerminal is designed to work with the Apple Personal Modem, the Apple Modem 1200, and the Apple Modem 300. The Apple modems are compatible with a few other “intelligent” modems—modems that can be commanded from the keyboard—like the Hayes Smartmodem 1200™ and the U.S. Robotics Auto Link 212A™.

If you’re using another type of modem, you’ll need special cables or adapters, and not all of MacTerminal’s features (such as dialing and hanging up the phone) may work correctly. Consult your authorized Apple dealer for help in choosing the correct equipment. Read the modem manual for installation instructions and information about special features you need to be aware of. If you want to read more about modems in general and the Apple modem in particular, turn to the section “More About Modems” in Chapter 3.

About Direct Connection

If you’re attaching your Macintosh directly to another computer, you’ll need special cables designed for that purpose. For example, you can purchase special cables for a direct Macintosh-to-Macintosh XL hookup. Consult your authorized Apple dealer or a data communications specialist where you’ll be hooking up the Macintosh.

Getting Started

Once you've installed the modem or directly attached the other computer to your Macintosh, you're ready to use MacTerminal in a communications session.

The rest of this chapter provides a general overview of what you might expect when you set up MacTerminal and start a session. When you actually begin using MacTerminal, you'll find most of the procedures you need in Chapter 2, "Using MacTerminal." If you should use MacTerminal in unique situations that aren't covered in Chapter 2, you'll find Chapter 3, "MacTerminal Reference," a good source of information about the capability of each command in the application.

■ The Flow of Work

The following pages take you through a typical series of steps for setting up a communications session for the first time using a new MacTerminal document. Here's a summary.

1. Start MacTerminal and open a new MacTerminal document.
2. Change the document's settings to match those of the other computer. (If you use one of the specialized documents provided on the MacTerminal disk, most of this step is taken care of for you.)
3. Save the document's settings.
4. Make contact with the other computer.
5. If you're communicating to a host computer, complete a sequence of steps, called **logging on**, for identifying yourself (and sometimes your Macintosh) to the other computer.
6. Send files to the other computer, or draw information from it.
7. Terminate the communications session.

What's a MacTerminal Document?

A MacTerminal document is like the document of any other Macintosh application—you can open it, move it and resize it, name it, and save it on a disk. But a MacTerminal document differs in a significant way. The document lets you set up communication with another computer, and provides a display area in which you see and work with incoming or outgoing data.

If you'd like, you may start your MacTerminal disk, open a new document, and take a look at the contents of the window. Here's how.

Note: If you have a hard disk connected to your Macintosh, see "Using MacTerminal With a Hard Disk," in Chapter 3, before opening a new MacTerminal document.

1. Be sure the Macintosh keyboard and mouse are firmly attached, and then turn on the Macintosh.
2. Insert the disk into the disk drive. The MacTerminal disk icon, named Terminal, appears on the desktop. It's highlighted to show that it's selected and ready for the next action.
3. Choose Open from the File menu (or double-click the icon) to open the Terminal disk icon. In the MacTerminal window, you see the MacTerminal application as well as the sample documents and the System Folder.

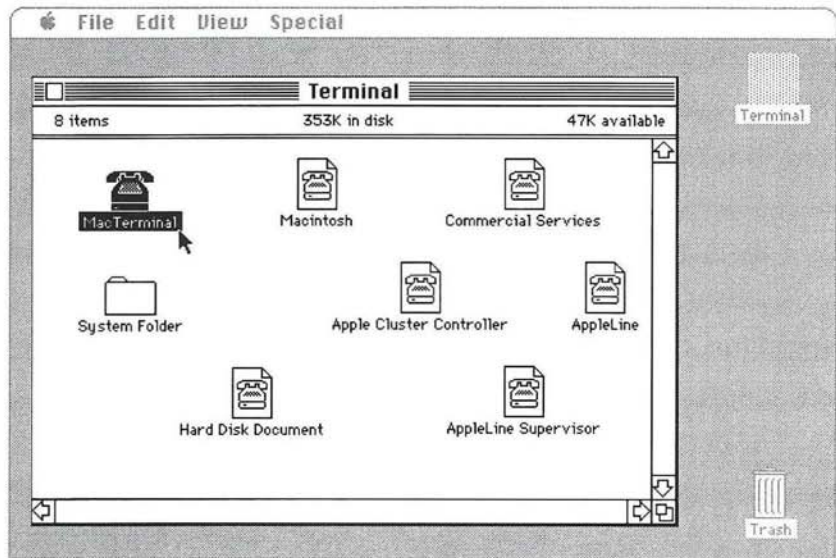

4. Click MacTerminal and choose Open from the File menu (or double-click MacTerminal) to open a new MacTerminal document. If you have a hard disk other than Apple's HD20, and if you have a modem connected to the Printer port on the back of your Macintosh, then open the Hard Disk document.

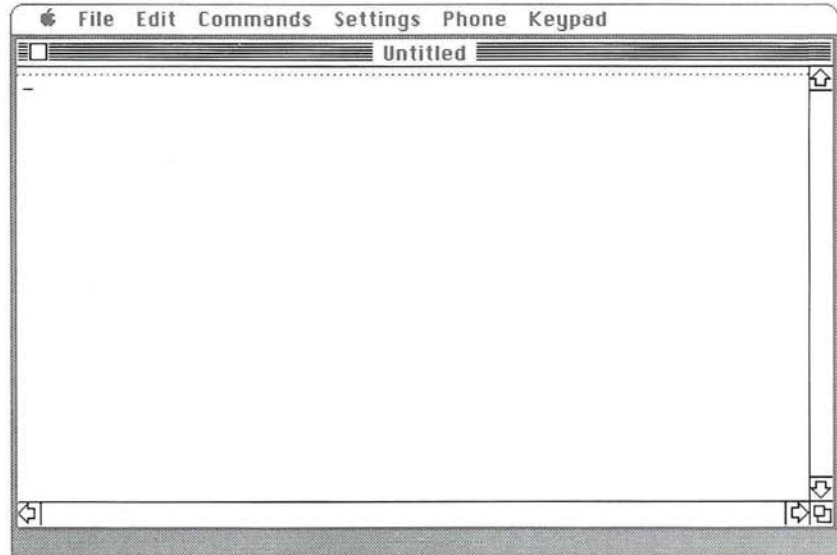

Your communications session with another computer takes place in the **terminal display area**. The **menu bar** contains the commands to set up the terminal and start a session. The **cursor** indicates the position where incoming or outgoing data appear in the terminal display area. You can use the **scroll bars** to see data that's scrolled off the top (above the dotted line) or off the right side of the terminal display area.

Because a MacTerminal document is a "terminal" screen, some of the editing features you're used to in other applications aren't available in a MacTerminal document. You can use only Copy and Paste; Cut and Undo work only in desk accessories. There's no insertion point that you click to position; instead, the cursor moves along as the characters appear on the screen. Backspace alone may or may not delete characters depending on the way you set it up.

After you set up the MacTerminal document to match the communications parameters of the other computer, you save the document with its settings and use it each time you want to connect to the computer you created it for.

Setting Up a MacTerminal Document

Once you've opened a MacTerminal document, you use the commands in the Commands, Settings, and Phone menus to set up a communications session. Suppose you want to send a MacWrite document to a friend who has an Apple IIe or to your company's mainframe computer. You'll need to know the communications parameters for these computers and set MacTerminal up accordingly. If you can't find out what the parameters are, use the preset ones for a new document and see what happens when you start a session. Then turn to "Troubleshooting" in Chapter 3 and try the possible solutions to whatever problem you encounter.

The Commercial Services document on the disk is already set up to communicate with information services such as THE SOURCE, CompuServe, and Dow Jones News/Retrieval. All you need to do is enter the service's telephone number, called the **access number**, and perhaps change the speed at which you're sending and receiving information (the **baud rate**).

The Macintosh document is preset to communicate with another Macintosh, Macintosh Plus, or Macintosh XL using MacTerminal 1.1. The document is set up for a modem connection. You'll change that if your Macintosh is directly connected. With a modem, all you do is enter the access number and dial.

The Hard Disk document helps you avoid potential problems using MacTerminal with hard disk drives other than Apple's HD20. Read "Using MacTerminal With a Hard Disk," in Chapter 3, before you use MacTerminal if you have another hard disk drive.

If you're using MacTerminal to emulate an IBM 3278, you'll use the AppleLine and AppleLine Supervisor documents, or the Apple Cluster Controller documents. Refer to Appendix C for information about AppleLine and Appendix D for information about the Cluster Controller.

Setting Up Compatibility

You can start setting up MacTerminal with any of the commands in the Settings menu, but you may want to start with the Compatibility settings because that's where you set most of the communications parameters. You choose Compatibility from the Settings menu and change the options by clicking the option title, or the circle or square, and then confirm the settings by clicking the OK button (or cancel your choices by clicking the Cancel button).

These options specify how your data is transmitted and received

These options let MacTerminal know what's attached to the Macintosh

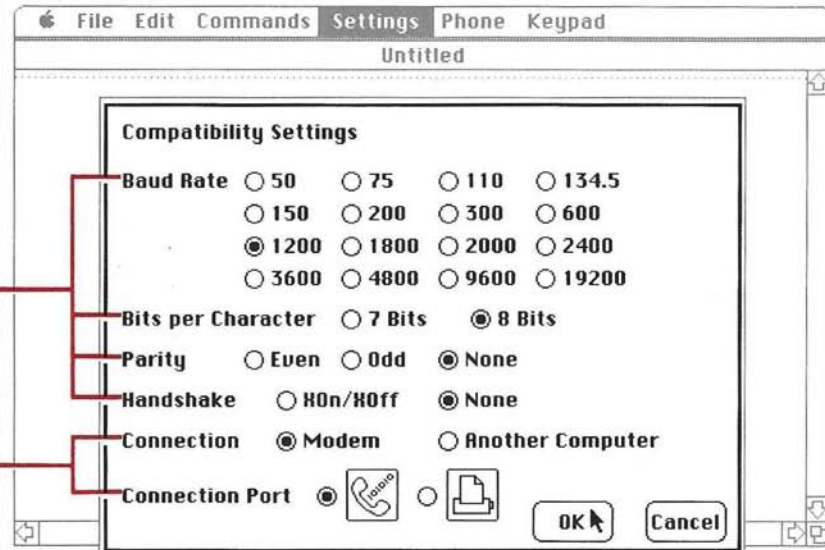

You don't need to know what each option means to set up your document, but if you're curious, refer to Chapter 3, "MacTerminal Reference," for a description of each option.

Unfortunately, not all data communications manuals refer to the compatibility options in exactly the same way. Baud rate is a standard expression, but you'll also see *bps* (bits per second) for baud rate. **Bits per character** is sometimes referred to as a 7-bit or 8-bit word. For **Handshake**, you may see *enable XOn/XOff*.

Some manuals refer to two parameters called **full duplex** or **half duplex**. These terms describe how a signal is sent along the transmission lines. Duplex means *two-way*. Full duplex means you can both send and receive, at the same time. Half duplex means you can do only one at a time—either send or receive.

MacTerminal is preset for full duplex, so you don't need to change anything if the other computer requires that setting. If the other computer specifies half duplex, you'll check the option **Local Echo** in the Terminal settings dialog box, described in the next section.

If you're communicating with a modem, your choice of baud rate is limited by the slowest modem on either end. If yours is a 300-baud modem and the other modem has a 1200-baud capacity, you have to use 300 for the baud rate setting. Directly connected computers can communicate at much higher baud rates; if you're connected to a VAX computer for example, you can use 9600 baud.

Setting Up Terminal Features

You choose the Terminal command to set the terminal type that MacTerminal will emulate and to set some of its special features. The preset options for a new document reflect a typical setup for communications with most larger systems, including the same commercial information services the Compatibility options are set for. You probably won't need to change any of the options unless you're communicating with another personal computer or working with data (such as charts or tables) wider than 80 columns.

Choose among a DEC VT100, a TTY, or an IBM

Set your preferences for these

For IBM 3278 terminal only

Check this to display the VT100 status lights

Check these if the remote computer doesn't provide the feature—most do

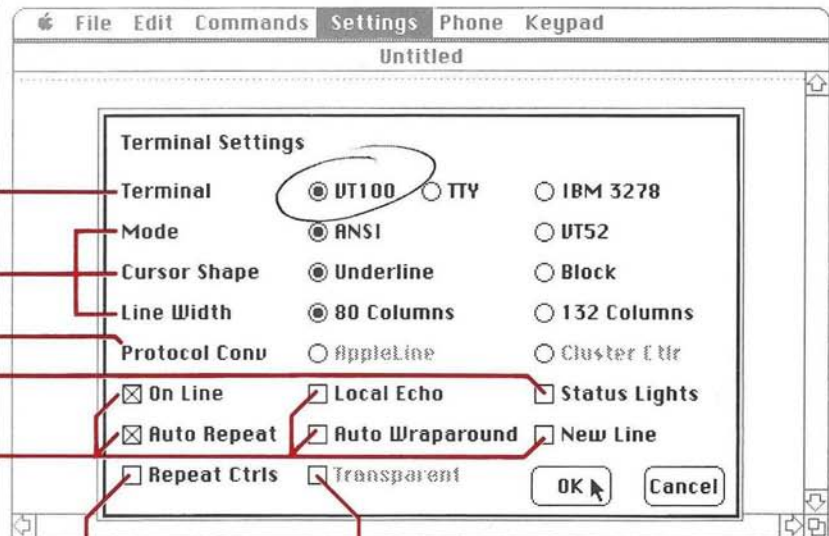

Check this to have a control character like Return repeat when you hold it down

Check this to see nonprinting characters (TTY only)

The DEC VT100 is preset as the most likely choice for terminal type. It's a more sophisticated terminal than the TTY, and many larger systems can work with its special features. Remember, when you're communicating with a large computer, the terminal simply provides access to that computer's data bases, applications, and storage capacity. A more sophisticated terminal like the DEC VT100 lets you use more sophisticated programs on the other computer—for example, a full-screen word processing application.

If a remote computer can't take advantage of a DEC VT100, choose TTY—a simple teletype-like terminal that understands a carriage return but not much else. If you're communicating with an IBM mainframe, choose IBM 3278.

When you change the terminal type, other options remain bold or dim depending on whether or not they work with the terminal type you've selected.

If you're communicating with another personal computer, you'll probably check the **Auto Wraparound** and **New Line** options. Most large modern computer systems provide these two features, but you can set MacTerminal to provide them if the other computer doesn't. You check Local Echo if you're communicating with another personal computer, or whenever the other computer specifies half duplex. Leave it unchecked if the other system specifies full duplex.

Sometimes it's easier to know how to check the Terminal options by seeing how incoming data appears on the screen when your communications session gets started. Then, if you see problems, refer to "Troubleshooting," in Chapter 3, to correct them.

If you want to know more about any of these options, refer to the option under "Terminal," in the section "Settings Menu" in Chapter 3.

Ask
Mike

Preparing to Transmit a File

You can send any Macintosh file to another Macintosh, Macintosh Plus, or Macintosh XL. The term **file** refers to any amount of information stored as a unit on the disk—for example, a document or a system file.

If the other computer can't work with Macintosh documents, you can send **text files**—documents you save as text, without pictures and without most format, font, or style information. **Text files (also called ASCII files)** are in a form almost all computers can understand. Many Macintosh applications give you the choice in the Save As command in the File menu of saving the document as it is or as a text file. For instance, in MacWrite, the Text Only button allows you to save a text file. In Multiplan®, the SYLK button does so.

Some applications automatically change a document to a text file when you save it. You'll never notice the difference when you work in the document, but you can send the file without saving it specifically as a text file. Refer to the application's manual for information about sending its documents to another computer.

The options in the File Transfer command let MacTerminal know what kind of transfer method you're using and what kind of software is at the other end.

ask ??

Make
93

File Transfer Settings

Settings for Pasting or Sending Text:

Delay Between Chars 60ths Second

Delay Between Lines 60ths Second

Word Wrap Outgoing Text

Settings for saving lines off top:

Retain Line Breaks

Save Screens Before Clearing

File Transfer Protocol

Text

MacBinary

HModem Text

MacTerminal 1.1

Straight HModem

OK Cancel

The settings for **pasting** or **sending** text govern its speed and arrangement. Once you set the same baud rate on both computers, using the Compatibility Settings, the computers can usually keep up with each other. On rare occasions, you may need to go farther. For instance, if you jump your cursor from the top left to the bottom right of the screen, and click, a receiving computer may not be able to keep up with the rush of data about the cursor's position. Data gets lost. If this happens to you, then—very gently—try experimenting with delays between lines, then between characters, until you find a setting that works.

In some situations, you may want to make your text easier for someone else to read at the other computer, by breaking lines after a word rather than in the middle of one; if so, check Word Wrap.

If you're receiving and saving information, and have already chosen the Command menu option to Record Lines Off Top, you may want to have MacTerminal save the Return characters sent at the end of each line—or eliminate them. For instance, if you plan to copy this text into MacWrite, which interprets every Return character as the end of a paragraph, you'll want to get rid of the Returns at the end of every line. How? Uncheck Retain Line Breaks.

If you intend to save your entire communications session, and you are receiving whole screens of information at a time from a mainframe, be sure you've already selected Record Lines Off Top, on the Commands menu; then check Save Screens Before Clearing in the File Transfer Settings. Some applications clear the screen frequently, without scrolling the lines off the top—so, without this command, your information would be lost. This way, in a few minutes, you may accumulate lots of data on your disk.

If you get a message that your disk is full, and you still want to record lines or save screens, choose Save As on the File menu, and use Eject and Drive to shift to a new disk with more room. When you've saved your file, turn Record Lines Off Top back on, and choose Save Screens Before Clearing again.

The **File Transfer** protocol refers to the conventions used to send or receive a file. Essentially, a protocol is an agreement between two computers about how they'll exchange data.

- The Text transfer method sends or receives files that contain only text, a sequence of ASCII characters without any information about format or font. Text is a fairly reliable way to exchange information between computers, but if there's an error in transmission, it won't be corrected or pointed out. When emulating an IBM 3278 talking to a mainframe, use Text.
- The MacBinary transfer method can transfer any Macintosh file (a document, an application, or a system file) to or from any computer that supports a protocol called XModem. The XModem protocol, originally developed by Ward Christensen, is an agreement to send data and keep on sending data until it gets there; it also checks errors, to make sure your file arrives intact. You can use MacBinary to transfer files from a Macintosh to an information service such as CompuServe™, and, if you want, from there to another Macintosh. Before you receive a file this way, you must use the Receive File option in the File menu.
- The XModem Text method works with computers that use the XModem protocol, but do not understand the formatting information in a Macintosh file. Unlike mere Text transfer, this method checks for errors. It also keeps your formatting intact, by sending a line feed signal after each Return. (The line feed tells the other computer to move down to the next line before starting the next line of text.) When you are receiving text, XModem Text strips those line feeds out. To receive a file by using this protocol, be sure to select Receive File on the File menu.
- The MacTerminal 1.1 transfer method allows you to transfer any type of file between two Macintoshes running MacTerminal. The Macintosh document that comes with your MacTerminal disk is already set to this option.
- The Straight XModem method is only for programmers. If you're not sure of what you're doing, avoid using this method. This method transfers the data portion of a Macintosh file, along with format, fonts, sizes, styles, graphic art, and page breaks, to another computer that supports the XModem protocol. To receive such a file, select Receive File on the File menu.

Entering the Access Number

If you're using a modem to communicate with the other computer, you choose Phone Settings from the Phone menu and enter the other computer's access (telephone) number to set up MacTerminal to call the other computer.

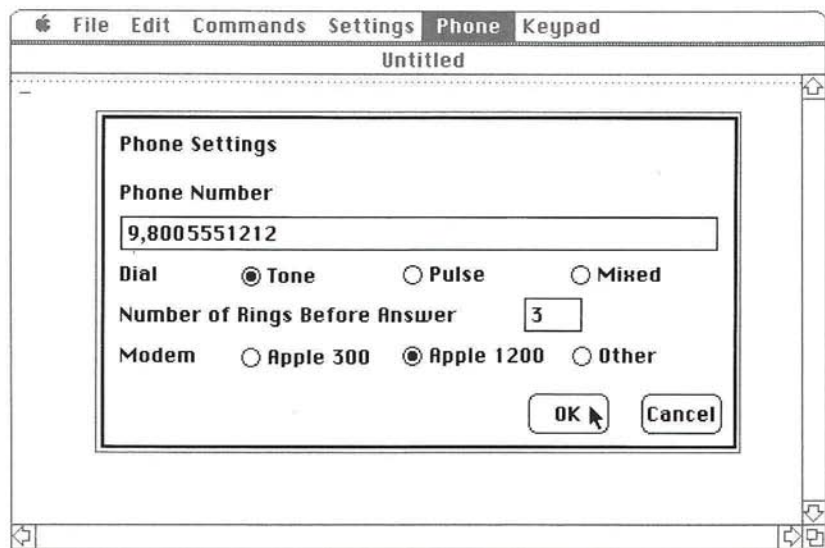

The other options in this dialog box let you specify the type of phone system in your area, the number of times you want your phone to ring before your modem answers it (used for receiving a call from another computer), and the speed of the Apple modem you're using. As with other dialog boxes, you'll find detailed information about each option in Chapter 3, "MacTerminal Reference."

Saving the Settings in a MacTerminal Document

Once you've set up a MacTerminal document so you can communicate with a particular computer, you may want to save the settings by choosing Save As from the File menu. Give the document the name of the computer service or person you set it up for. Macintosh stores the document on the disk, and a document icon appears in the Finder. Each time you want to connect to that computer—to call the Dow Jones News/Retrieval service, for example, to find out how your stock is doing—you'll be able to open the document with the proper settings and access number.

You may find it convenient to start the session this way. Then, before actually dialing or making connection, save the document under a new name, indicating its date or contents. That way your original document with the settings and access number will always come up uncluttered, ready to use again.

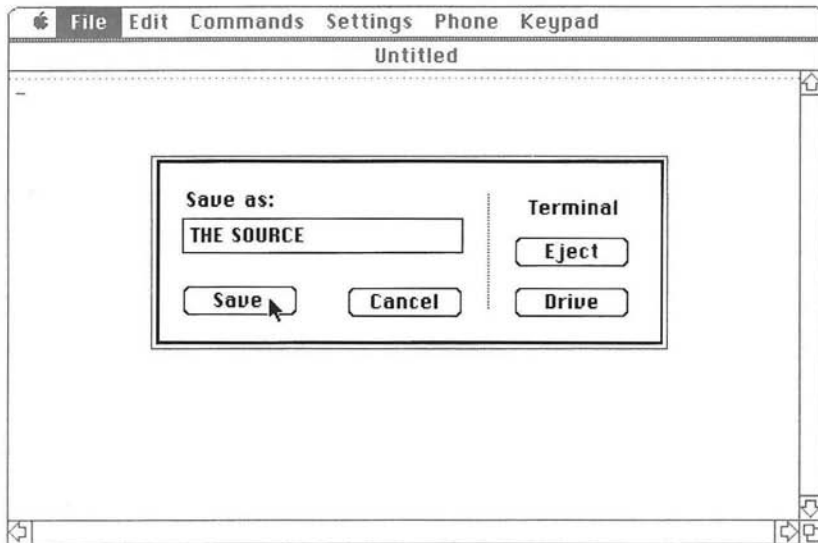

Making the Connection

Once you've set up the MacTerminal document, you're ready to connect to the other computer and start a communications session. If your Macintosh is directly connected to the other computer and is set to communicate with it, you can start sending and receiving information at any time. If you're using a modem, you start a session by turning on the modem and choosing Dial on the Phone menu.

If the Apple modem's volume is up enough, you hear connection noises as the modem is dialing and a brief high-pitched sound when the computer answers. MacTerminal tells you whether it's made a connection or not. If it doesn't make a connection the first time, always try again. If the problem persists, turn to "Troubleshooting" in Chapter 3 and try the solutions presented there.

■ Receiving a Call From Another Personal Computer

When you're expecting to receive a call from another computer, you make sure your Settings match those of the other computer, turn the modem on, use Phone Settings in the Phone menu to specify the number of times you want the phone to ring before the modem answers, and then choose Wait for Call in the Phone menu. If you're using the MacBinary, XModem Text, or Straight XModem protocols, choose Receive File on the File Menu. When the call comes in, the modem answers the phone, and MacTerminal confirms the connection. Usually, you'll type something (or send a standard Answerback Message, discussed in Chapter 3) to let the other person know you're there and to indicate that you're ready to send a file or to receive one.

If you'd like to know more about your telephone's relationship with your modem, read "More About Modems" in Chapter 3.

■ Logging On

Once MacTerminal is connected, your next steps depend on whether you're connected to a host computer or to another computer that's communicating only with you (probably another personal computer).

When you connect to another personal computer, you and the person at the other end can begin communicating by typing on the keyboard or by sending files. When you connect to a host computer, you have to complete a series of steps defined by the host computer to identify yourself—a procedure called logging on—before you can read data, work in an application, or send and receive files.

Most host computers ask you for your name (or account number) and the password you received when you opened an account with the system. Some ask you to identify your terminal. The queries are usually in the form of a prompt—an abbreviated question. All the proper responses should be in the host computer's user's manual. Except for the password, you see your responses on the screen. The other computer usually doesn't echo back the password; that's to protect your account from pirates or other unsavory, unauthorized users.

Log-on procedures are usually very precise. If you type a space where one's not indicated or use a lowercase letter when uppercase is called for, the host computer probably won't accept your entry. Instead, the host computer sends you a more-or-less polite message telling you to try again or get help.

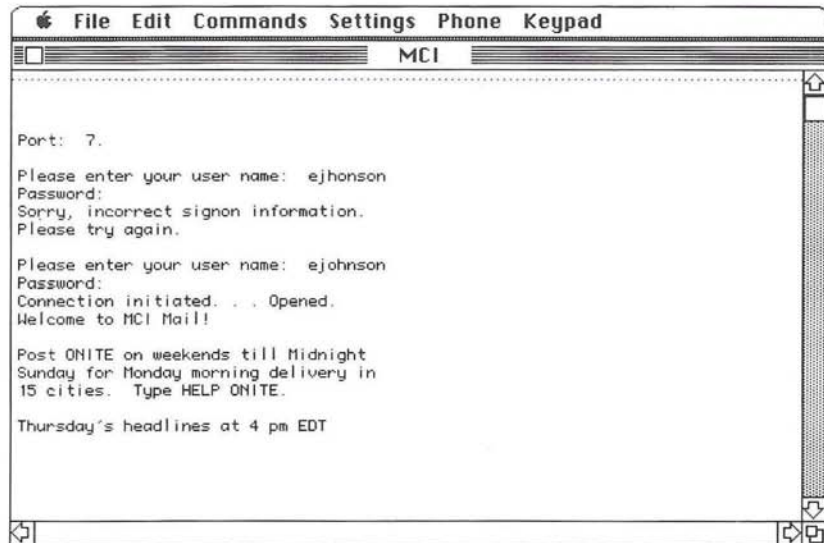

The Macintosh Keyboard

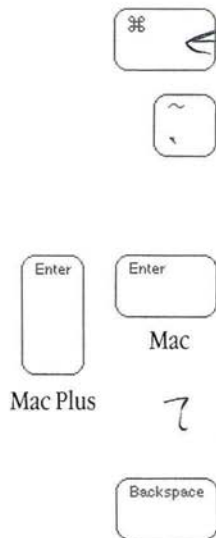

Some log-on sequences may ask you to use a key like **Control**, **Escape**, or **Break**. When you're using MacTerminal, these keys on the Macintosh keyboard act as special keys:

- The **Command key**, located to the left of the space bar, becomes the **Control key**.
- The key located on the top left of the keyboard becomes the **Escape key**. You can still get the grave accent (`) by pressing the Command key along with this one; you can get the tilde (~) by pressing the Command and Shift keys along with this one.
- The Enter key, located to the right of the space bar on a Macintosh, or to the right of the numeric keypad on a Macintosh Plus, becomes the **Break key** for a DEC VT100 terminal type. When you're using MacTerminal as a DEC VT100, use the Return key when the other computer asks you to press Enter. When you're using MacTerminal as an IBM 3278, the Enter key remains an enter key and doesn't change its function.
- The Backspace key backs your cursor up one character. By using the Keyboard command on the Settings menu, you can determine whether it just backs up, or deletes the character it passes over.

See Appendix A for a layout of Macintosh and Macintosh Plus keyboards when you're using MacTerminal.

You use the Control key by holding it down while pressing some other key. For example, if a service requires you to use Control-C to log off, hold down the Control (Command) key and press the letter C. You use the Escape key by pressing the key and *then* pressing some other key. For instance, Escape-1 means to press Escape, release it, and then press 1.

A Communications Session

You can start sending and receiving files immediately when you're communicating with another personal computer. With a host computer, however, it's a little more complicated.

When you've successfully logged on, most host computers welcome you in some way and present you with the main menu of options available on the system. When you choose one by typing its number or command, you often get another menu of choices within that main topic. This is a very common way for large complex programs to guide you through available data bases, applications, and communications networks.

You may look up some statistics, arrange an airline flight, check the facts on a new invention, leave a message for a friend. You may sign on to another computer, and use its specialized program for a few minutes, arranging a manufacturing process. You may participate in a conference, respond to questions posted on an electronic bulletin board, or buy stock.

Sometimes a communications session can get muddled up, through no fault of your own. There are a lot of possibilities for problems when two different computers are trying to communicate over a long distance. If you should start to receive what looks like hieroglyphics instead of text, and you don't know why, and nothing you do seems to make a difference, you can use the Reset command from the Commands menu to chuck it all and start over. Reset erases everything in the terminal display area and puts the settings back to the way they were when you last saved the document.

■ Saving Data for Later Use

As soon as you start to receive information from the other computer, MacTerminal is preset to record the data for later use. The Record Lines Off Top command from the Commands menu (when it's chosen, it changes to Don't Record Lines Off Top) tells MacTerminal to save data in the document as the data scrolls off the top of the terminal display area. MacTerminal activates the appropriate scroll bar as soon as there's data recorded off the top of the screen.

If you've already named the document and saved the settings, MacTerminal also saves the data to the document on the disk. If you haven't saved the settings, MacTerminal stores the data in a temporary place until you do save them, or throws the data away if you don't.

The Don't Record Lines Off Top command tells MacTerminal to throw away lines of data as they scroll off the top of the terminal display area. If MacTerminal has recorded data and you decide you don't want the data, you can use the Clear Lines Off Top command from the Commands menu to tell MacTerminal to erase everything it has recorded above the dotted line.

Some mainframe applications send you a screen full of information and then, without scrolling up, erase it and replace it with the next screen. To capture this information, select the command Record Lines Off Top, and then select File Transfer on the Settings menu and check Save Screens Before Clearing.

You can select any data in the terminal display area or recorded above the dotted line. You can copy a selection into the Clipboard and paste it into a document from another application, into a desk accessory such as the Note Pad (if it fits on one Note Pad page), or even back into MacTerminal. Or you can print the selection. Pasting any selection into MacTerminal during a communications session sends the data to the other computer.

Some applications accept the contents of a MacTerminal document directly without your having to select and copy the data. Once you save the document and quit MacTerminal, you move the document to the disk that has the application you want to use with that document. Select both the MacTerminal document icon and the application icon (click one icon, hold down the Shift key, and click the other). Choose Open from the File menu. A new document for the application opens with the data from the MacTerminal document in its window.

When you receive a file by using the Text protocol, you see the text appear on your screen. When you receive a file by using any other protocol, you do not see the text on your screen; instead, you see a gauge indicating how much of the file has been transferred from the other computer to your disk.

Once you have received a file from another Macintosh by using any protocol except Text, you can see the contents of the file this way: you start by quitting MacTerminal. You will see the icon or name for your new file in the Finder. You can now open this file if you have the appropriate application on the disk.

When you've received a file from *any other* computer by using any protocol other than Text, and you want to open the file, quit MacTerminal. In the Finder, you'll see a "blank page" icon. Click the icon, hold down the Shift key and click MacWrite. Then choose Open from the File menu.

When you have received and saved a text file, you can open it this way: Launch the application (such as MacWrite). Close the Untitled document, then select Open on the File menu. The document should appear on the list. Select it. Your application may then need to convert the pure text file into a file of its own kind; if so, you'll be asked whether you want Returns to indicate line breaks or paragraphs. To save the format, choose Paragraphs.

You also need to consider the Retain Line Breaks option in the File Transfer command (Settings menu) when you're saving incoming data. This option lets you decide whether MacTerminal should save or delete the Return character that most remote computers send at the end of a line. You'll choose to save or delete the Return character depending on how the application to which you're copying uses it.

For example, in MacWrite a Return character marks the end of a paragraph; you don't use Return at the end of lines within a paragraph. If you copy text to MacWrite from MacTerminal, and the text has a Return character at the end of each line, MacWrite will treat each line as a separate paragraph. So when you're copying data from MacTerminal to MacWrite you uncheck Retain Line Breaks.

Sending Data to Another Computer

When you're in a communications session, you can use the Send File command in the File menu to send files from your Macintosh to any other computer with the appropriate communications software.

If you've set the File Transfer protocol to MacBinary, MacTerminal 1.1, or Straight XModem, the Send File command presents a list of all Macintosh files, including documents, text files, applications, and system files. If you set up MacTerminal to send text files to most other computers (Text or XModem Text), you'll see a list of text files only. You can send a file by double-clicking the file name, or by choosing the file name and then clicking the Send button.

During a communications session, the Paste command sends to the other computer whatever text you've previously cut or copied into the Clipboard, just as if you'd typed the text on the keyboard. You can compose a short note on the Note Pad desk accessory, cut or copy the note to the Clipboard, prepare the other computer to receive a file, choose Paste, and off it goes. See "Sending a Small Amount of Text" in Chapter 2 for more information.

Using Another Computer's Applications

In addition to data bases, bulletin board services, and communications networks, many large systems have applications for you to use—a word processing or spreadsheet application, budget forecaster, and so on. If you choose to work in one of these applications, you'll quickly see the advantage of the DEC VT100 terminal type. Unlike the TTY terminal, the DEC VT100 terminal lets you do things like highlight text or scroll anywhere in the terminal display area.

Some host computers have applications that use a full screen of data at a time. Text editors are the most common full-screen applications. If you're using one, read "Using a Full-Screen Application," in Chapter 3, for more specific information.

Terminating a Session

If you've been communicating with a host computer, always terminate a communications session by typing the remote computer's **log-off command**. Then, if you're using the Apple modem, choose Hang Up from the Phone menu. Many host computers terminate the connection after a few minutes if there's no activity on your end. (If you're deep in thought, type any character just to let the remote computer know you're there.) Some computers don't terminate a connection until they receive a log-off command from you. You may have turned off the Macintosh and the modem and gone to bed, but the other computer doesn't know that and is charging you for connect time as you doze off.

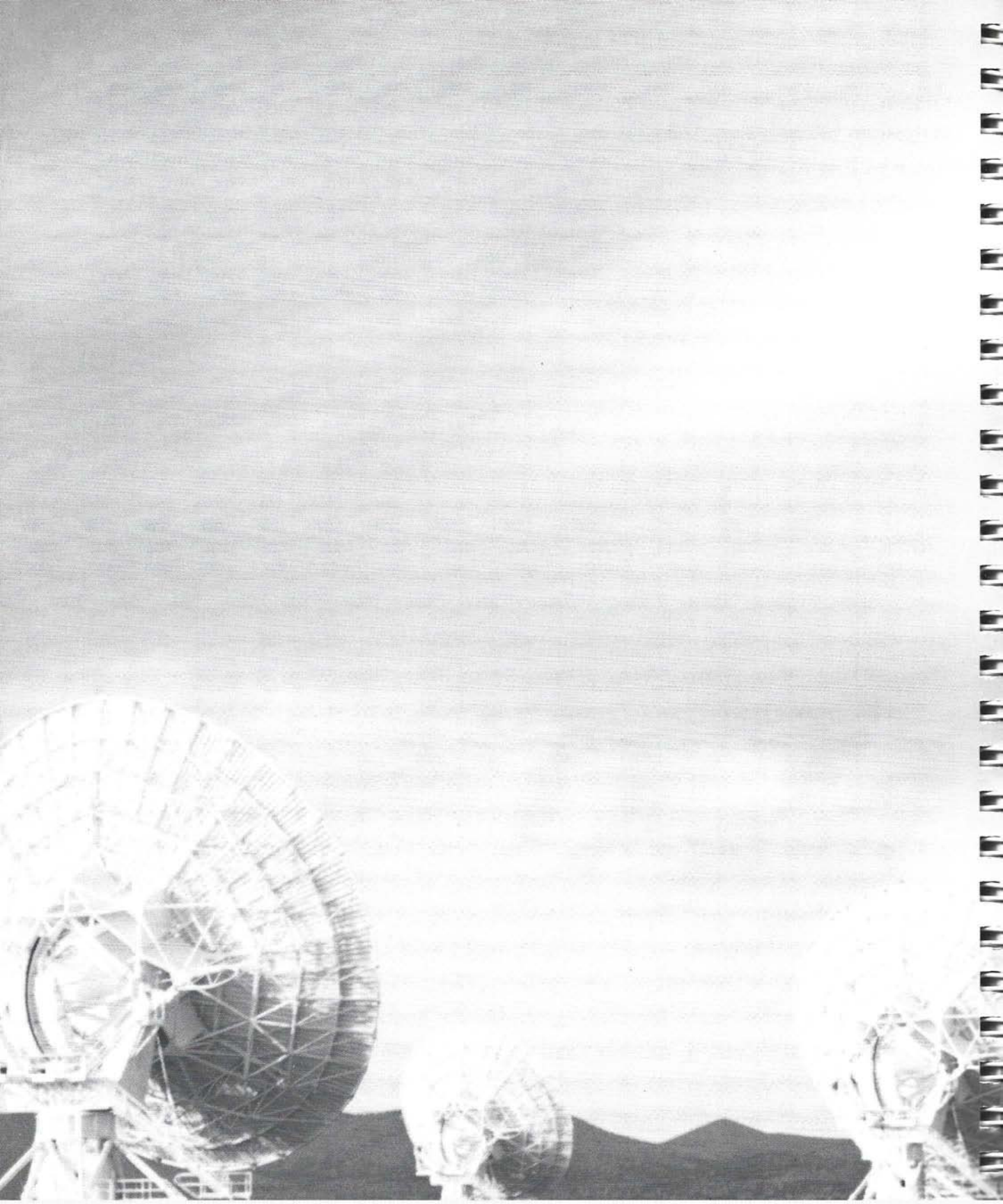

Chapter 2

Using MacTerminal

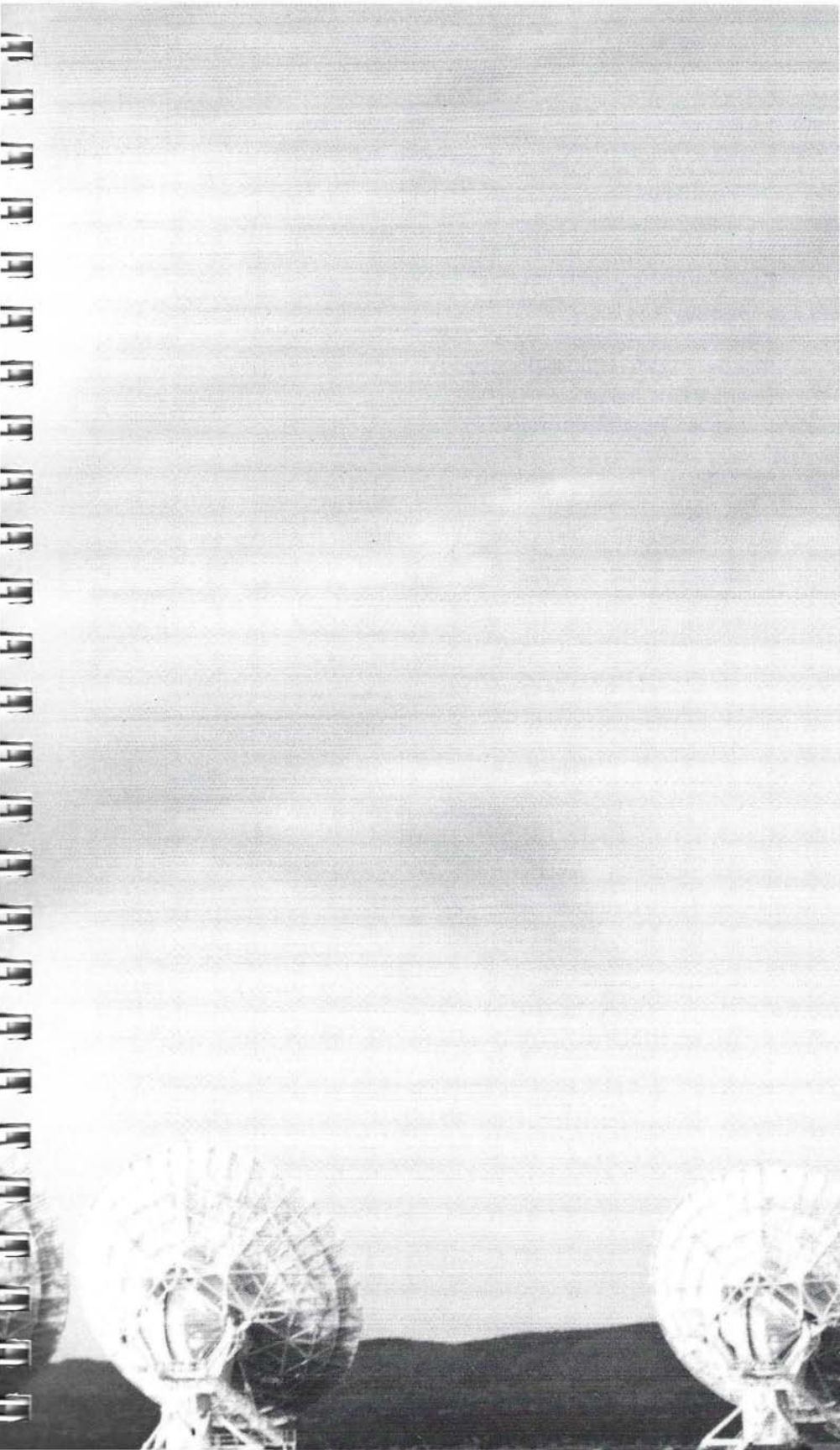

Contents

29	Introduction
30	Setting Up a New MacTerminal Document
32	Starting a Communications Session
34	Sending a File
36	Sending a Small Amount of Text
38	Communicating With Another Macintosh
40	Communicating With Another Personal Computer
42	Copying Data From MacTerminal to Another Document
44	Printing
45	Opening MacTerminal Documents
46	Saving a Document
47	Copying a Document or Application From One Disk to Another

Introduction

This chapter provides step-by-step instructions for most of the things you'll do with MacTerminal. You don't have to read the chapter in any particular order; each topic is independent of the others or includes cross-references where needed.

The commands in the menus mentioned in this chapter are explained in detail in Chapter 3, "MacTerminal Reference."

Setting Up a New MacTerminal Document

A new MacTerminal document is preset to communicate with most popular commercial information services. Each preset option is marked in its circle or box. With any document, you can use the preset options or modify them. To change a setting from one option to another, click the option name, the circle, or the square. Some features have only on and off options: click an unchecked feature to turn it on; click a checked feature to turn it off. To confirm the settings in a dialog box, click the OK button (or, to cancel, click the Cancel button).

The MacTerminal application disk comes with six documents already set up for you—Macintosh, Commercial Services, Hard Disk, AppleLine, AppleLine Supervisor, and Apple Cluster Controller.

The Macintosh document is preset so that you can communicate with another Macintosh or a Macintosh XL using MacTerminal 1.1. (See “Communicating With Another Macintosh” later in this chapter.) The Commercial Services document is preset to communicate with most public information services and is set up as a new MacTerminal document. Some information services may require slightly different settings—for instance, MCI Mail requires that you turn on Handshake (Settings menu: Compatibility). If you’re communicating with an IBM mainframe, use the AppleLine or the Apple Cluster Controller documents to communicate through these intermediary devices. (See Appendix C, “Installing the AppleLine,” and Appendix D, “Installing the Apple Cluster Controller.”)

If you are using a hard disk other than the Apple Hard Disk 20, and if your hard disk is connected to the Modem port, use the Hard Disk document. For more information, see “Using MacTerminal With a Hard Disk,” in Chapter 3.

1. Open a new MacTerminal document.

Select MacTerminal and choose Open from the File menu (or double-click MacTerminal).

The application presents you with a new document called “Untitled.”

2. Set the Terminal and Compatibility options in the Settings menu.

To set the Terminal options, follow these steps:

- Set the Terminal type.
- You can leave the remaining options as they are for most host computers.
- For another personal computer, you may need to check Auto Wraparound, Local Echo, and New Line—features that most larger systems would provide. See “Communicating With Another Personal Computer” later in this chapter.

To set the Compatibility options, follow these steps:

- Set the options for Baud Rate, Bits per Character, and Parity to match the other computer’s settings.
- If the other computer uses a Handshake protocol, and if you’re transmitting data at speeds over 1200 baud, check XOn/XOff.
- Set Connection to Another Computer if you’re communicating by direct cable rather than a modem.
- The Modem Port option is preset and the only option recommended for use with either a modem or a direct connection. If you have a hard disk, see “Using MacTerminal With a Hard Disk” in Chapter 3.

3. Decide whether you want to save incoming data.

If you don't, select Don't Record Lines Off Top on the Commands menu.

If you do want to save the information, select Record Lines Off Top. If you are receiving data from a mainframe that sends one screen after another, clearing them without scrolling off the top, select File Transfer on the Settings menu, and check Save Screens Before Clearing.

4. If you want to send a file, choose the File Transfer command from the Settings menu.

- Choose a protocol.
- If you want to end lines between words, choose Word Wrap Outgoing Text.

For details on these settings, see "Setting Up to Transmit a File" in Chapter 1, and "File Transfer Settings," under "Settings Menu," in Chapter 3.

5. If you're communicating by modem, choose the Phone Settings command from the Phone menu.

- Type the phone number (called the access number) of the other computer, including a number to get an outside line and the area code if needed. Type a comma after the number for an outside line. Example: 9,(415)5551212.

You can type parentheses and spaces if it makes it easier for you to read the number. The Apple modem ignores everything except numbers and commas.

- Set Dial by checking Tone, Pulse, or Mixed, depending on the telephone system in your area. See the "Phone Menu" section in Chapter 3 for more information.

- If you're expecting a call from another computer, specify a number between 1 and 255 for the Number of Rings Before Answer option. This option tells the modem the number of times you want the phone to ring before the modem answers it. A setting of 0 tells the modem not to answer the phone at all.

- Check the Modem option to match the modem you're using. Be sure you've checked Modem in the Compatibility dialog box in the Settings menu.

6. Save the settings before starting a communications session.

Choose Save As from the File menu, name the document, and then click the Save button.

See "Saving a Document" later in this chapter for further instructions.

Starting a Communications Session

If you're using a modem, you start a communications session by using the Dial command in the Phone menu to dial the other computer's phone number (called the access number). Once connected, if the other computer is a host computer, you log on to get "into the system." If you're involved in one-to-one communication with another personal computer, you can immediately start typing to each other, or sending and receiving files.

1. Open a MacTerminal document and set it to communicate with the other computer.

If you're communicating by modem, be sure you've specified the Connection and Connection Port in the Compatibility dialog box and that you've typed the phone number and specified proper settings in the Phone Settings dialog box (Phone menu).

If your Macintosh is directly connected to the other computer, go to the last paragraph of step 4 of these instructions.

See "Setting Up a New MacTerminal Document" earlier in this chapter.

2. Choose Dial from the Phone menu if you're originating a call through an Apple modem.

MacTerminal informs you that the Apple modem is dialing the number you entered and whether or not the call is answered. With the Apple modem's volume up enough, you can hear the dialing sounds and a brief high-pitched tone when the computer answers.

If you don't make a connection the first time, try again. If you still don't connect, check that the baud rate is correct (Settings menu: Compatibility). Also see "Troubleshooting" in Chapter 3.

3. If you're receiving a call through an Apple modem, choose Wait For Call.

If you are using the MacBinary, XModem, or Straight XModem File Transfer protocols, select Receive Files on the File menu.

The Apple modem answers the incoming call after the number of rings you've specified in the Phone Settings menu.

4. Once connected, start typing to another personal computer, or log on to a host by responding to its prompts.

Prompts differ from one host computer system to another; however, you'll almost always be asked for a name or an account number and a password. In addition, some may require a terminal identifier, found in the guide to the system or information service. And if you're connecting to the service through a phone network like Telenet® or Tymnet®, you'll be asked to identify which service you want.

If a prompt is repeated, it usually means that you made a typing mistake: You typed a space where you shouldn't have, or used lowercase when only uppercase letters work, or pressed Return once when you were supposed to press it twice. The list of possible mistakes isn't endless, but it can be frustratingly long. Try again.

If a log-on sequence asks you to use a control character like Control-C, hold down the Command key and press C.

If you're not connecting with a host computer, but with one that's communicating only with you—a coworker's Macintosh XL, for example—you can usually start sending and receiving information as soon as both computers have started their communications application and set the parameters, and one has called the other.

5. Prepare the other computer to send or receive data.

■ If you've connected to a host computer, get into the "insert mode" or "send mode" in whatever subsystem you want—a bulletin board, a word processing application, or a spreadsheet application, and so forth.

Or

■ If you're not communicating with a host computer, but with one that's communicating only with you, let the person on the other end know you're ready to send or receive data.

Sending a File

With MacTerminal, you compose what you want to send—a letter, report, table of figures, and so forth—in the appropriate Macintosh application. MacTerminal can send or receive either the entire document or only the text of a document, depending on the type of software at the other end. See “Setting Up to Transmit a File” in Chapter 1 and “File Transfer Settings” in Chapter 3 for an explanation of file transfer methods.

1. Open a MacTerminal document.

If necessary, set the appropriate Compatibility and Terminal options from the Settings menu.

See “Setting Up a New MacTerminal Document” earlier in this chapter.

2. Choose File Transfer from the Settings menu.

- If you are sending a Macintosh file to another Macintosh running MacTerminal, choose MacTerminal 1.1.
- If you are sending to an Apple II, choose XModem Text.
- If you are sending a complete Macintosh file to an information service that supports the XModem protocols, and you want another Macintosh to be able to collect the file there, choose MacBinary.
- If you are a programmer sending the binary version of the data portion of a Macintosh file to a computer that supports the XModem protocol, use Straight XModem.
- If you are sending only the text to a computer that does not support the XModem protocol, use Text.
- If you are emulating the IBM 3278, use Text.
- If you need to make sure that lines break between words rather than within them, choose Word Wrap Outgoing Text.

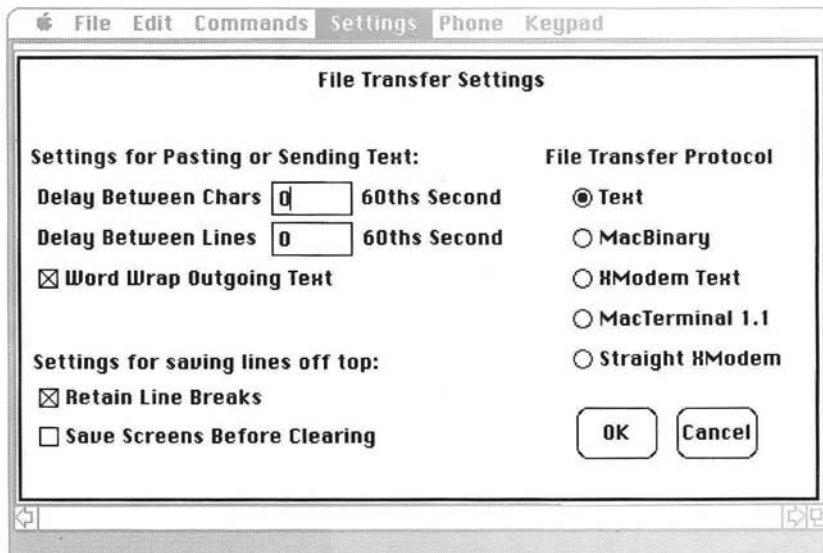

3. Start a communications session and prepare the other computer to receive a file.

■ Open a prepared document.

Or

■ Open a New document, choose Compatibility on the Settings menu, and specify the Connection and Connection Port.

■ If using the phone lines, choose Phone Settings on the Phone menu, type in the phone number, and specify the settings. Then choose Dial.

■ Log on if necessary.

For details, see "Starting a Communications Session" earlier in this chapter.

4. Select Send File from the File menu.

■ If you checked Text or XModem Text on the File Transfer dialog box, only text files (ASCII files) show up on a list for you to choose from. Select the file you want to send. (MacTerminal documents are text files, and appear on the list.)

■ If you checked any other protocol, you see a list of all the files on the disk—documents, system files, and so forth. Select the one you want to send.

If you have the hierarchical filing system that accompanies the Macintosh Plus or Hard Disk 20, you may need to open folders to find the file you want.

If the file you want is on a different disk, click Eject and insert the other disk, or insert the disk in the external drive. A similar list of files appears for this disk. If you have disks in both drives, click the Drive button to switch between them.

5. Click the file you want to send and click the Send button (or double-click the file name).

If you're sending a file with the MacTerminal 1.1, MacBinary, XModem Text, or Straight XModem protocol, a gauge appears in the window with a moving marker showing the progress of the transmission. If you're sending a text file, you'll usually see the text appear in the window. If you don't see anything, check Local Echo in the Terminal dialog box (Settings menu) and try sending again.

To stop sending a file, hold down the Command key and press the period (.) key.

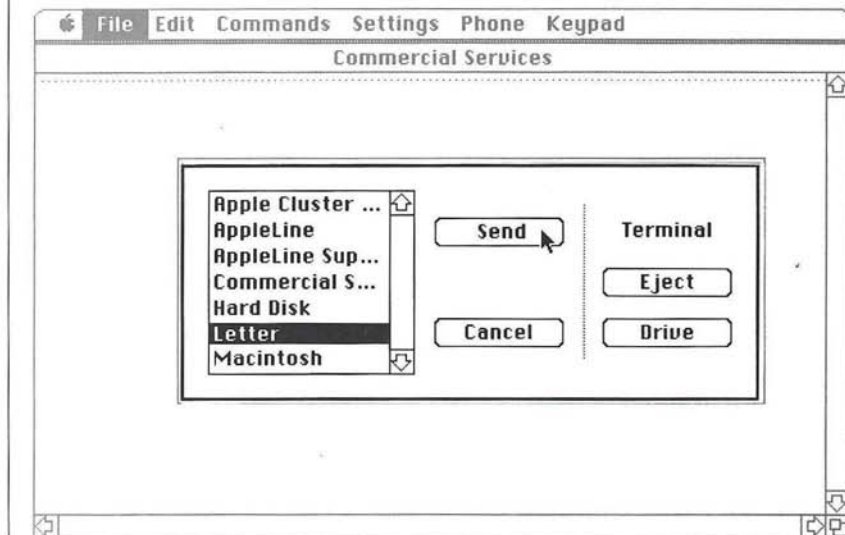

Sending a Small Amount of Text

You can send text by cutting or copying it to the Clipboard and pasting it into the MacTerminal document. This is a quick way to send text you've composed on the Note Pad. Type a note on the note page, select the text (you can select only one page at a time), copy or cut it, close the Note Pad, and choose Paste. MacTerminal sends the text to the remote computer just as if you'd typed the text in the MacTerminal display. By the way, when writing in the Note Pad, use the regular characters; don't use the foreign characters and symbols available by pressing Option at the same time that you press a key. MacTerminal does not transmit those extra characters.

1. Select text you want to send and choose Cut or Copy from the Edit menu.

The text appears in the Clipboard. The contents of the Clipboard remain until the next cut or copy, until you turn the Macintosh off, or until its power is interrupted in some other way.

2. Open a MacTerminal document.

If necessary, set the appropriate Compatibility and Terminal options from the Settings menu.

In the Terminal dialog box, check Auto Wraparound and New Line to see the text you're sending properly displayed in the MacTerminal display area. Check Local Echo if you're sending to another personal computer.

See "Setting Up a New MacTerminal Document" earlier in this chapter.

3. Choose File Transfer from the Settings menu.

Set the File Transfer options as follows:

- Leave File Transfer Protocol as is; for this operation, MacTerminal ignores that setting.
- Leave Delay Between Chars and Delay Between Lines set at 0 unless Macintosh is sending data faster than the other computer can receive it.
- Check Word Wrap Outgoing Text if you want MacTerminal to break a line at the end of a word rather than between characters.

4. Start a communications session and prepare the other computer to receive data.

See “Starting a Communications Session” earlier in this chapter.

5. Choose Paste from the Edit menu.

MacTerminal sends the text selection to the other computer, which will often echo the selection back to the terminal display area. If it doesn't, check Local Echo in the Terminal dialog box from the Settings menu.

Communicating With Another Macintosh

When using MacTerminal to communicate between two Macintoshes, or between a Macintosh and a Macintosh XL, you can send and receive any Macintosh file—a document, application, text file, or system file—by choosing File Transfer on the Settings menu, then checking MacTerminal 1.1.

The MacTerminal disk provides a document named Macintosh that's preset to communicate between Macintoshes. Using this document, you'll only need to enter the phone number and perhaps change the baud rate.

Also, before you actually call the other computer, choose the Save As command in the File menu and save the document's settings under a new name. That creates an empty document, all set to communicate with the other computer. From then on, start with that document, and—before collecting any data in it—save it again under a name that recalls the day's date, or the contents. That's so you won't clutter up your original "empty" document.

1. On each Macintosh, open the Macintosh document and choose Compatibility on the Settings menu.

Set the Compatibility options for both computers as follows:

- Baud Rate—300 or 1200, depending on the slower modem; if the computers are directly linked, use 19200 (or any baud rate that works with the communications link).
- Check the appropriate Connection and Connection Port options, depending on what's attached to the Modem Port or Printer Port.

2. Choose Terminal from the Settings menu.

Set the Terminal settings for both computers as follows:

- Check VT100.
- Check On Line.
- If you're going to be sending with the Paste command, check Auto Wraparound and New Line, and go to step 4 of these instructions.

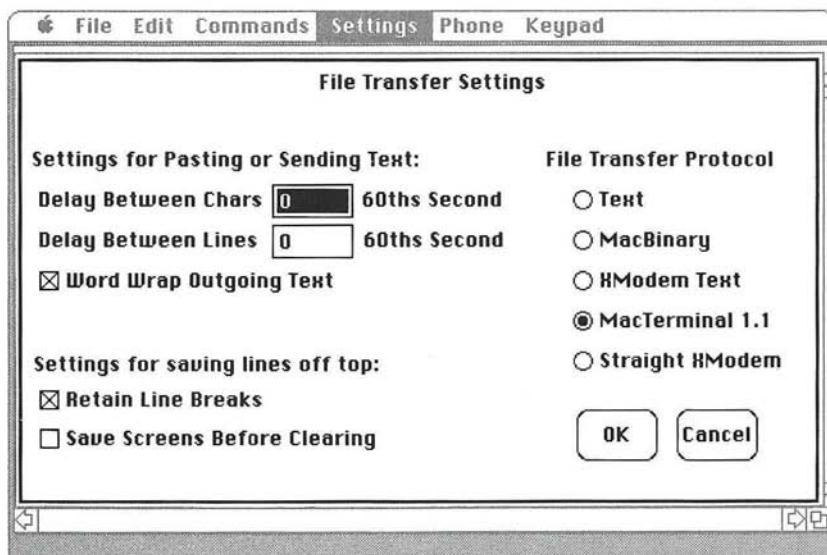

3. Choose File Transfer from the Settings menu.

If you're sending a file with the Send File command, go to the Settings menu, choose File Transfer, and make sure that the settings for both computers are as follows:

- Choose MacTerminal 1.1 as the File Transfer Protocol.
- Check or uncheck Retain Line Breaks and Word Wrap Outgoing Text, depending on your preferences.

By the way: If you're pasting a selection from the Clipboard, MacTerminal ignores the File Transfer Protocol.

4. Make the connection.

- If using phone lines, choose Phone Settings on the Phone menu and type in the phone number of the other Macintosh. Then choose the Dial command on the Phone menu.
- If connecting directly, make sure the cable is in place.

5. Send a file, receive one, or type a message.

- Just type. Anything you type on either computer immediately shows up on both screens.
- You can send a file by using the Send File command.
- You can send a short passage by using the Paste command.
- You can receive a file sent by the other Macintosh.

For more information on sending data, see "Sending a File" and "Sending a Small Amount of Text" earlier in this chapter.

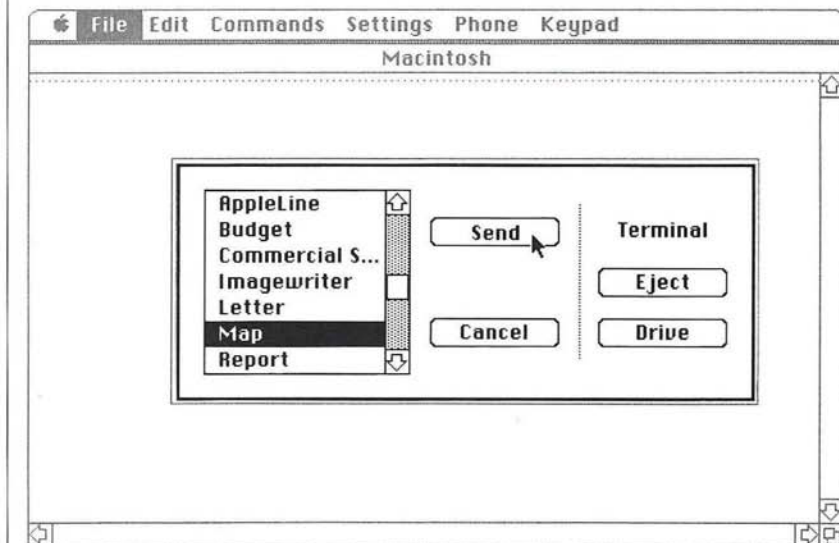

Communicating With Another Personal Computer

When communicating between a Macintosh and another personal computer, the communications parameters must be the same for both computers. You may need to experiment with the Compatibility and Terminal settings before successfully sending or receiving data. Once you've had a successful transmission, be sure to save the MacTerminal document so you can use the same settings again.

Because direct communications like this require that you arrange with the other person a time when you'll be sending or receiving data, most people prefer to use communications networks, such as MCI Mail. A remote computer functions as the clearinghouse for incoming and outgoing "mail" or files. At your convenience, you can send files to others and pick up files sent by others on the same network.

1. Open a new MacTerminal document and choose Compatibility from the Settings menu.

Communications parameters differ depending on the terminal emulator and modem used by the other computer. Here's a common configuration to start with:

- Baud Rate: 300.
- Bits per Character: 7 bits.
- Parity: None.
- Handshake: None.
- Connection and Connection Port settings depend on what's attached to the Macintosh's Modem and Printer ports.

2. Set the Terminal Settings for both computers as follows:

- Check TTY as the recommended terminal type.

You'll probably want to set the terminal type to TTY to avoid problems you might encounter if the other computer's application can't communicate with a more sophisticated terminal like the DEC VT100.

- Check Local Echo, Auto Wraparound, and New Line.

These features properly display the text in the MacTerminal display area. If the other computer provides these features, and you've also checked them in MacTerminal, you'll see the problem as the data appears in the terminal display area. See "Troubleshooting" in Chapter 3 to fix the problem.

3. Choose File Transfer from the Settings menu.

- Choose Text or XModem Text as File Transfer Protocol.
- Check Word Wrap Outgoing Text if you want MacTerminal to break a line at the end of a word rather than between characters.

4. Make the connection.

- If using phone lines, choose Phone Settings on the Phone menu and type in the phone number of the other Macintosh. Then choose the Dial command on the Phone menu.
- If connecting directly, make sure the cable is in place.
- Log on if necessary.

See "Starting a Communications Session," earlier in this chapter, for more details.

5. Send a file, receive one, or type a message.

- Just type. Anything you type on either computer immediately shows up on both screens.
- Send a file by using the Send File command.
- Send a short passage by using the Paste command.
- To receive using the Text or MacTerminal 1.1 protocols, do nothing at your end. If you are using the MacBinary, XModem Text, or Straight XModem protocols, set Receive File on the File menu.

For more information on sending data, see "Sending a File" and "Sending a Small Amount of Text" earlier in this chapter.

File Transfer Settings

Settings for Pasting or Sending Text:	File Transfer Protocol
Delay Between Chars <input type="text" value="0"/> 60ths Second	<input checked="" type="radio"/> Text
Delay Between Lines <input type="text" value="0"/> 60ths Second	<input type="radio"/> MacBinary
<input checked="" type="checkbox"/> Word Wrap Outgoing Text	<input type="radio"/> HModem Text
	<input type="radio"/> MacTerminal 1.1
	<input type="radio"/> Straight HModem
Settings for saving lines off top:	
<input checked="" type="checkbox"/> Retain Line Breaks	
<input type="checkbox"/> Save Screens Before Clearing	
	<input type="button" value="OK"/> <input type="button" value="Cancel"/>

Copying Data From MacTerminal to Another Document

A new MacTerminal document is preset to record incoming or outgoing data as the data scrolls off the top of the terminal display area (although you can set it not to). You can select all or any part of the data in the MacTerminal document and then copy it to a desk accessory or the document of another Macintosh application. If you've logged on to a data base, for example, and received a table of statistics, you can put the table into a report you're working on in a Macintosh word processing application or spreadsheet.

When you receive files with the MacBinary, XModem Text, and Straight XModem protocol from another Macintosh or any other computer, MacTerminal displays a gauge (rather than the text) that shows you the progress of the transmission. Once the transmission is complete, the file appears in the Finder when you quit MacTerminal.

Some applications let you move the contents of a MacTerminal document directly into their documents without selecting and copying the data. You save your document to the disk that has the application you want. Then you quit MacTerminal and return to the Finder. Select both the MacTerminal document icon and the application icon (click one icon, hold down the Shift key, and click the other). Choose Open from the File menu. A new document for the application opens with the data from the MacTerminal document in its window.

1. Open a MacTerminal document and set its options so you can communicate with the other computer.

See "Setting Up a New MacTerminal Document" earlier in this chapter.

- Be sure Record Lines Off Top from the Command menu is chosen, and you see Don't Record Lines Off Top.
- On the Settings menu, choose File Transfer. If you are going to receive from a mainframe that sends a screenful of information at a time, check Save Screens Before Clearing. In the same dialog box, choose whether you want to retain line breaks or not. Refer to "Retain Line Breaks" in Chapter 3.

2. Start a communications session, and prepare the other computer to send files.

See "Starting a Communications Session" earlier in this chapter.

When you begin to receive data, MacTerminal saves it as it scrolls off the top of the display area.

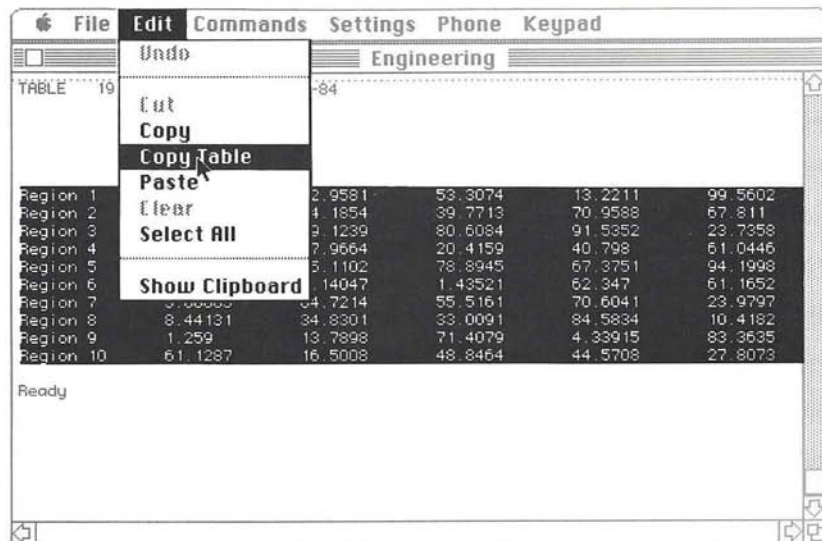

3. Select the data you want to copy.

- Choose Select All in the Edit menu to select all data in the document.

Or

- Select a portion of the data by dragging across it or by selecting an insertion point at one end of the text you want to select, positioning the pointer at the other end of the data (scroll if necessary), holding down the Shift key, and clicking where you want to end the selection.

4. Choose Copy or Copy Table from the Edit menu.

- Choose Copy if you're copying paragraphs of text.

- Choose Copy Table if you're copying a table to Excel, shown below, or to certain other spreadsheet applications.

The Copy Table command changes the spaces between tabular text to tabs so that a table appears in the correct format when you paste it into some spreadsheet applications that require tabs between columns.

When you choose Copy or Copy Table, MacTerminal places a copy of the selection on the Clipboard.

5. Quit MacTerminal.

- Terminate the connection, if you want to, by typing the log-off command(s) if the other computer requires you to. Quit MacTerminal by choosing Hang Up from the Phone menu if you're using a Modem and then choosing Quit from the File menu.

6. Open the other application's document and paste the data where you want it.

- The application for the document you're opening must be on a disk in one of the disk drives or you won't be able to open the document.

- Open a new or existing document for the application you want to use.

- Follow the pasting procedures for the application.

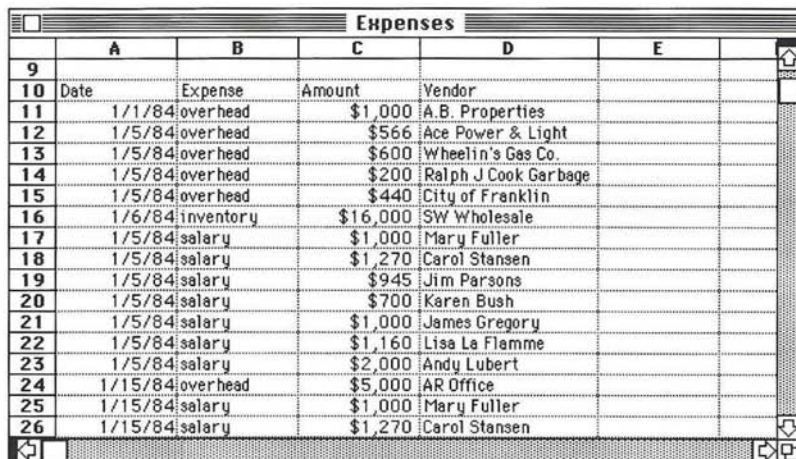

	A	B	C	D	E
9					
10	Date	Expense	Amount	Vendor	
11	1/1/84	overhead	\$1,000	A.B. Properties	
12	1/5/84	overhead	\$566	Ace Power & Light	
13	1/5/84	overhead	\$600	Wheelin's Gas Co.	
14	1/5/84	overhead	\$200	Ralph J Cook Garbage	
15	1/5/84	overhead	\$440	City of Franklin	
16	1/6/84	inventory	\$16,000	SW Wholesale	
17	1/5/84	salary	\$1,000	Mary Fuller	
18	1/5/84	salary	\$1,270	Carol Stansen	
19	1/5/84	salary	\$945	Jim Parsons	
20	1/5/84	salary	\$700	Karen Bush	
21	1/5/84	salary	\$1,000	James Gregory	
22	1/5/84	salary	\$1,160	Lisa La Flamme	
23	1/5/84	salary	\$2,000	Andy Lubert	
24	1/15/84	overhead	\$5,000	AR Office	
25	1/15/84	salary	\$1,000	Mary Fuller	
26	1/15/84	salary	\$1,270	Carol Stansen	

Printing

You can select data in a current MacTerminal document and print the selection, or you can select a MacTerminal document in the Finder and print any data you saved in it. You can also copy data to another application's document and print it from there.

If you have more than one printer attached to your Macintosh, you may need to select the one you want to use. Use Choose Printer or Chooser on the Apple menu.

1. Choose Page Setup from the File menu.

These settings are saved when you save the document.

If you're printing data wider than 80 columns, use the following settings:

Wide Orientation and US Letter for data up to 124 columns.

Wide Orientation and US Legal for data up to 132 columns.

You won't use the Tall Adjusted option in MacTerminal.

2. Select what you want to print.

Select by dragging (or by using Shift-click).

If you want to select more than what's in the terminal display area, click where you want to begin selecting; scroll if necessary; hold down the Shift key; and click where you want to end the selection.

To extend a selection, scroll if necessary, then hold down the Shift key and click where you want to end the selection.

Or

Choose Select All from the Edit menu to select all the data in the MacTerminal document.

3. Choose Print Selection from the File menu.

If you're printing on a single sheet at a time, click Cut Sheet and OK in the dialog box to start the printing process, and then click OK after each sheet is inserted. *Don't remove a sheet until the printing process is complete*; the ImageWriter must move through a sheet to the end of the page even if it isn't printing any text. See "Print Selection" in Chapter 3.

ImageWriter (1/11) OK

Paper: US Letter R4 Letter
 US Legal International Fanfold
 Computer Paper

Orientation: Tall Tall Adjusted Wide

Pagination: Normal pages No breaks between pages

Reduction: None 50 percent v2.0

Cancel

ImageWriter v2.1 OK

Paper: US Letter R4 Letter
 US Legal International Fanfold
 Computer Paper

Orientation

Special Effects: Tall Adjusted
 50 % Reduction
 No Gaps Between Pages

Cancel

Opening MacTerminal Documents

You open a new MacTerminal document or an existing one from the Finder or from a MacTerminal document by using the File menu.

To Open a New MacTerminal Document

From the Finder:

Select the MacTerminal application and choose Open from the File menu (or double-click the application icon).

Or, from a MacTerminal document:

Choose Close from the File menu to close the current document. A dialog box lets you name an untitled document or save any unsaved changes before closing.

Choose New from the File menu. A new MacTerminal document appears. You'll name it the first time you save it.

To Open an Existing MacTerminal Document

From the Finder:

Select a MacTerminal document; choose Open from the File menu (or double-click the document).

Or, from a MacTerminal document:

Choose Close from the File menu to close the current document.

Choose Open from the File menu. A dialog box appears.

If the document is on a different disk, click the Eject button and insert the other disk. If you have two disk drives, insert the disk in the other drive, or click Drive to switch between drives.

Select the MacTerminal document by clicking its name in the list of documents that appears.

Click the Open button, or double-click the document name.

To Quit MacTerminal

Choose Quit from the File menu.

A dialog box lets you name an untitled document or save any unsaved changes before quitting.

Saving a Document

MacTerminal only temporarily remembers changes you make to a document's settings; to keep these settings, save the document on the disk. When you save a document for the first time, its settings and current data are saved. From then on, MacTerminal automatically saves any data it's recording to the copy of the document on the disk. If you erase data in the document, MacTerminal automatically erases the same data on the disk.

- **Save As** lets you name an untitled document and save it either to the disk you started with or to another one. It also lets you rename the open document, creating a new document on the disk (under the new name) without replacing the old one.
- **Save** updates the copy of the document on the disk with the current changes. If the document is untitled, **Save** lets you name it and save it either to the disk you started with or to another one.

To Save an Untitled Document

- Choose **Save As** (or **Save**) from the **File** menu. A dialog box appears that lets you name an untitled document.
- Type a name for the document.

You can use any character or symbol on the keyboard except a Tab, Return, or colon (:). You can use uppercase or lowercase letters and put spaces between words.

- Click the **Save** button or press the **Return** key.

If the disk is full, you'll get a warning message. Save the document on another disk or remove some documents from the current one.

To Save a Document on a Different Disk

- Choose **Save As** from the **File** menu. (The **Save** command lets you save a document on a different disk only if you're naming the document for the first time.)

The current name of the document appears selected in the dialog box. To change it, type a new name.

- Click the **Eject** button and insert the other disk. If you have two drives, insert the disk in the other drive. If you've already inserted a disk in the other drive, click the **Drive** button to switch between disks.

- Click the **Save** button or use **Return**.

MacTerminal saves the document to the disk named in the dialog box. With one disk drive, you swap disks a few times until the save process is complete, ending with the original disk in the drive.

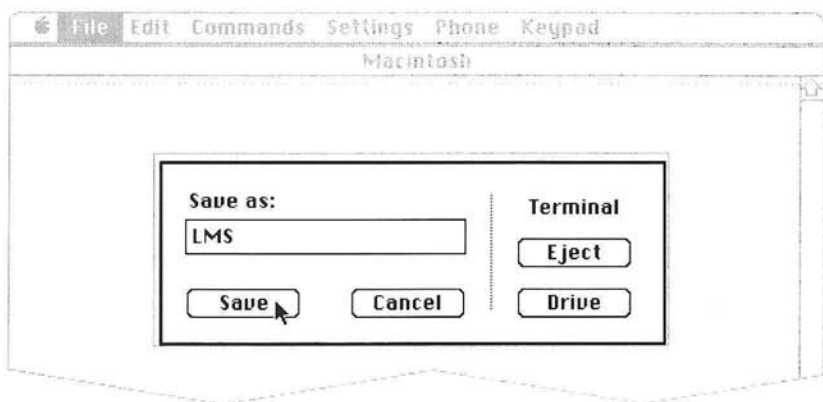

Copying a Document or Application From One Disk to Another

With MacTerminal, you send files that you've created in other Macintosh applications. If you find that you're frequently using an application to compose documents to send—MacWrite, for example—you may want to keep it on the MacTerminal startup disk or keep MacTerminal on another application's startup disk.

You can copy a document, folder, or application to a different disk as long as the icon of the disk you're copying to is present.

1. If necessary, insert the disk you want to copy to, so its icon will be present.

2. Select the icon that represents the document, folder, or application you want to copy.

If necessary, choose By Icon from the View menu, and scroll until the icon is visible.

You can drag or Shift-click to select more than one icon to copy.

Compare the size of the document or application to the space remaining on the destination disk.

- With the document or application selected, choose Get Info from the File menu. Note the number of bytes available after Size.

Some applications show you size in bytes, others in kilobytes or K (K is the number of bytes divided by 1,024 and rounded off), and some in both.

- Look in the upper-right corner of the destination-disk window for the amount of room on the disk (expressed in K—13K, for instance).

If the destination disk is too full, start a new disk or drag the files you don't want to the Trash icon and choose Empty Trash from the Special menu.

3. Drag the icon to the place you want the copy to go.

You can drag it to a folder icon, disk icon, folder window, or disk window.

The destination disk can be arranged by icon or by any other arrangement.

If you're using a one-drive system, the Macintosh presents a series of dialog boxes, asking you to insert alternately the disk you're copying from and the disk you're copying to.

If the destination disk already contains an item with the same name, you'll be asked to confirm that you want to replace the current contents with what you're copying.

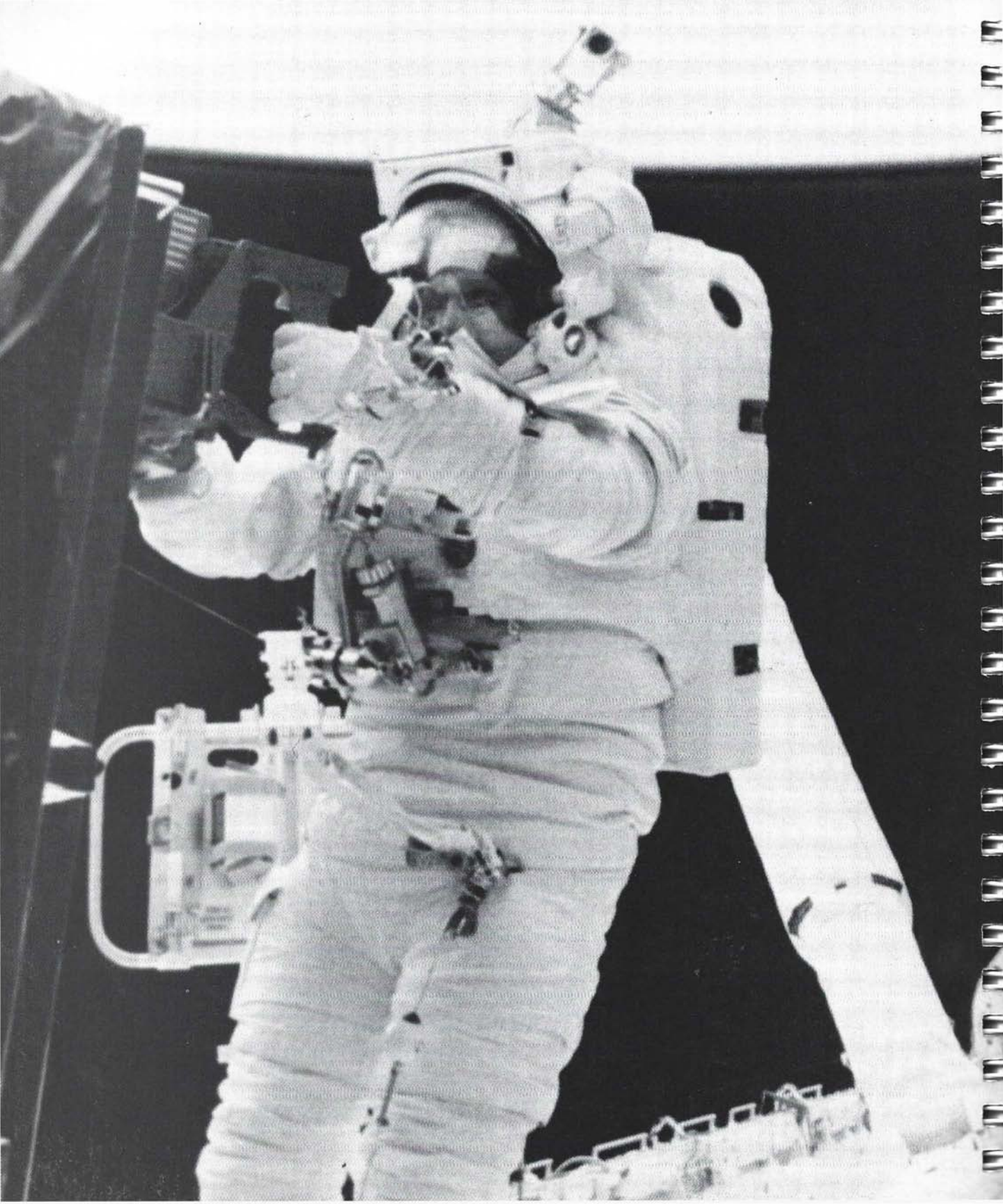

Chapter 3

MacTerminal
Reference

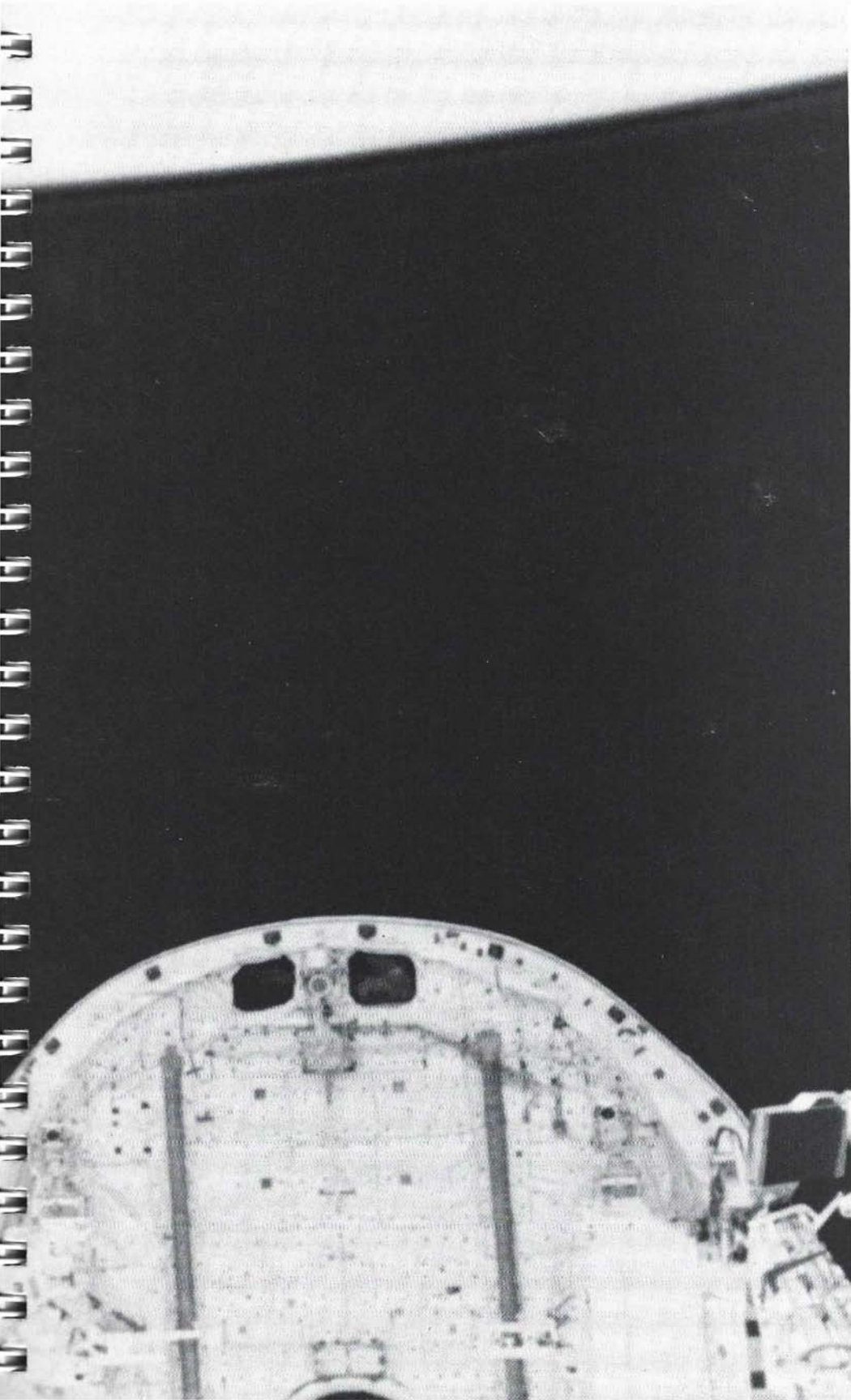

Contents

52	MacTerminal Commands
52	Apple Menu
53	About MacTerminal
53	Desk Accessories
54	File Menu
54	New
54	Open
55	Close
55	Save
55	Save As
56	Send File
58	Receive File
59	Page Setup
61	Print Selection
61	Quit
62	Edit Menu
62	Undo
62	Cut
62	Copy
62	Copy Table
63	Paste
63	Clear
63	Select All
63	Show Clipboard/Hide Clipboard
63	Commands Menu
63	Record Lines Off Top/Don't Record Lines Off Top
64	Clear Lines Off Top
64	Reset
65	Start Scrolling/Stop Scrolling
65	Unlock Keyboard
65	Settings Menu
66	Terminal Settings
66	Terminal
66	Mode
67	Cursor Shape
67	Line Width
67	Protocol Conv
67	On Line
68	Local Echo
68	Status Lights
69	Auto Repeat
69	Auto Wraparound

69	New Line
70	Repeat Ctrl's
70	Transparent
70	Compatibility Settings
71	Baud Rate
71	Bits per Character
71	Parity
71	Handshake
72	Connection
72	Connection Port
73	File Transfer Settings
74	Settings for Pasting or Sending Text
75	Settings for Saving Lines Off Top
76	File Transfer Protocols
77	Answerback Message
78	Character Sets
78	Currently Active
79	G0 Character Set
79	G1 Character Set
79	Keyboard Configuration
80	Show Tab Ruler/Hide Tab Ruler
81	Phone Menu
81	Dial
81	Hang Up
81	Wait for Call
82	Phone Settings
82	Phone Number
82	Dial
83	Number of Rings Before Answer
83	Modem
83	Keypad Menu
86	Using A Full-Screen Application
87	More About Modems
87	Compatible Modems
87	Commanding a Modem
87	Your Modem and Your Telephone
88	Using MacTerminal With a Hard Disk
89	Troubleshooting

MacTerminal Commands

In addition to the standard Apple menu, MacTerminal has six menus: File, Edit, Commands, Settings, Phone, and Keypad. The File and Edit menus contain the same basic commands for managing and editing documents that all Macintosh applications use, plus some extra commands specific to MacTerminal. And MacTerminal uses some of the basic commands in a unique way. For instance, because you can't cut data from a MacTerminal document, the Cut command in the Edit menu is active only for desk accessories. The last four menus—Commands, Settings, Phone, and Keypad—contain commands specific to MacTerminal.

Any command that requires additional information from you (or has helpful information for you) appears with three dots (...) after it. When you choose these commands, a dialog box appears with a message or with areas for you to enter information and check options. You click a button, such as OK or Save, or use the Return key to confirm the command. Clicking the Cancel button retracts the command and leaves the options as they were when you chose the command.

Commands or their options are dimmed if they're inappropriate at a given moment. For example, the Close command is dimmed if there's no open window on the desktop.

Apple Menu



The Apple menu provides you with information about the program and printer you're currently using, and your keyboard, plus any desk accessories residing in your system file.

About MacTerminal

This command shows you information about MacTerminal and your current communications session, such as the number of characters stored off the top of the terminal display area in the open document, and the amount of space free on the disk.

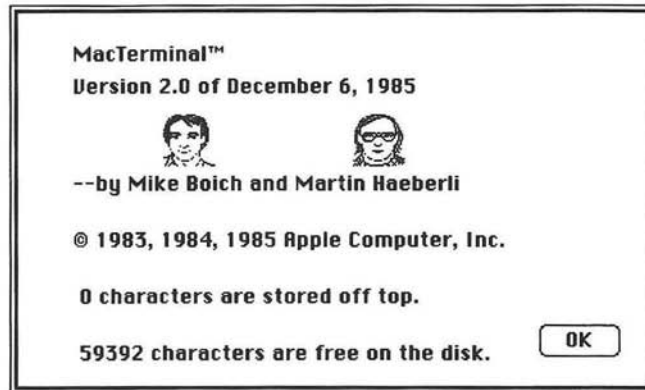

Desk Accessories

Choosing any of the desk accessories causes that accessory to appear on the desktop as the active window. You can use the Edit menu to cut (or copy) the information from most accessories and paste it into another accessory, a document of another Macintosh application, or a MacTerminal document. During a communications session, pasting into a MacTerminal document sends the data to the other computer, just as if you'd typed it on the keyboard.

The Note Pad is a useful accessory during a communications session when you don't want to take the time to open another application. You can compose a short note or message in the Note Pad during a session, cut or copy the note, and then send it by pasting it into a MacTerminal document. (See the section on the Paste command under "Edit Menu," later in this chapter.)

The desk accessory stays on the desktop as an active or inactive window until you close it, either with its close box or with the Close command from the File menu. *Macintosh*, your owner's manual, has instructions for using desk accessories.

File Menu

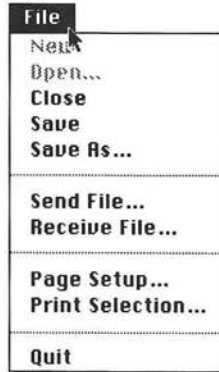

The File menu contains commands for managing documents while in the MacTerminal application.

New

Opens a new, untitled MacTerminal document. You can choose New only after closing the current document.

Open

Opens a document stored on a disk. A dialog box presents a list of MacTerminal documents on the disk named in the box. You open a document by clicking the document name and then the Open button (or by double-clicking the name).

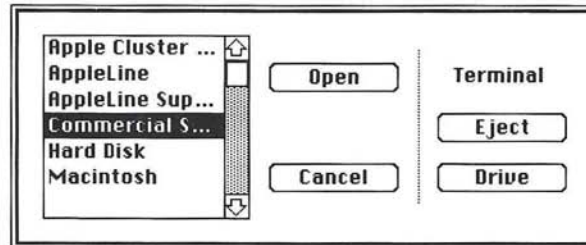

The Eject button ejects the disk named in the dialog box. If you have two disk drives with a disk in each and eject the disk named in the dialog box, MacTerminal automatically switches to the disk in the other drive and shows you its name and list of documents. If you insert a disk again into the empty drive, MacTerminal switches back to that disk.

The Drive button lets you switch between drives when you have more than one drive with a disk inside.

Close

Closes the active window. If the MacTerminal document window is the active window and you've changed settings or other information in the menu commands, a dialog box appears and gives you the opportunity to save the changes.

Save

Saves the document you're working on and its settings and lets you name and save an untitled document. Once you've saved a document, use this command when you've changed settings in the menu commands and want to save the changes on the disk. See "Save As," immediately following, for an explanation of naming a document and saving on a different disk.

The first time you save a document, MacTerminal saves any data in the document along with the settings. Afterward, if you set MacTerminal to record incoming data as it scrolls off the top of the display, MacTerminal records it in the open document and automatically saves it to the copy on the disk. (See "Record Lines Off Top" under "Commands Menu," later in this chapter.) If the other computer is a mainframe sending one screen full of information after another, you can save whole screens. (See "Settings For Saving Lines Off Top" under "File Transfer Settings" in Chapter 3.) You don't need to save your document regularly to save data, only to save setting changes. If you decide to erase data that MacTerminal has recorded in the open document, MacTerminal also erases it from the copy of the document on the disk. (See "Clear Lines Off Top" under "Commands Menu".)

Save As

Saves the document you're working on, its settings, and any data—under the name you specify and to the disk named in the dialog box. The Eject and Drive buttons let you save a document to another disk.

When you first name a document or save it under a different name, a new document is stored on the disk with that name, and a new icon is created in the Finder. Use the Save As command when you want to save the document you're working on as a separate document and keep the old version on the disk, or when you want to save a document to another disk (or do both).

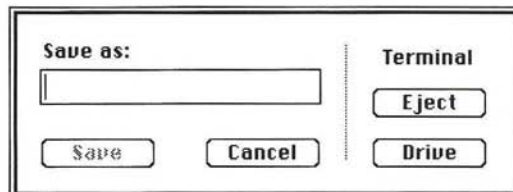

When you save an untitled document, a dialog box appears with a place for you to type a name. You can use any character except a colon, Return, or Tab in the name for the document. After naming a document, you save it to the disk named in the dialog box by clicking the Save button. If a document already exists with that name on the disk, you're asked to confirm that you want the document you're saving to replace the existing one.

The first time you save a document, MacTerminal saves any data in the document along with the settings. Afterward, if MacTerminal is set to record data, it automatically saves the data to the copy on the disk as it records the data in the open document. If you decide to erase data that MacTerminal has recorded, MacTerminal also erases it from the document on the disk. (See "Record Lines Off Top" under "Commands Menu, later in this chapter.)

The Eject button ejects the disk named in the dialog box. If you have two drives with a disk in each drive and eject a disk from one, MacTerminal automatically switches to the disk in the other drive and shows its name in the dialog box. If you insert a disk again into the empty drive, MacTerminal switches back to that disk.

The Drive button lets you switch between drives when you have more than one drive with a disk inside.

Send File

Sends a file from a disk to another computer. A dialog box presents a list of all appropriate files on the disk named in the box. The Eject and Drive buttons let you send a file from another disk.

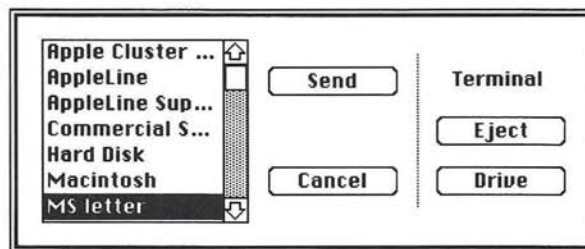

The types of files listed—documents, applications, text files, or system files—depend on the File Transfer protocol you checked in the File Transfer dialog box from the Settings menu.

- If you checked Text or XModem Text, only text files appear. (All MacTerminal documents are text files.)
- If you checked any other protocol, you see all the Macintosh files on that disk—documents, system files, and applications.

When you select a file, then confirm the command by clicking Send or pressing the Return key, MacTerminal sends the file to the other computer.

- If you're sending a file with the Text protocol, you may see the text displayed on your screen, if the other computer echoes it. (If the other computer doesn't, you can display the text by going to the Settings menu, choosing Terminal, and turning on Local Echo.)
- If you're using any other File Transfer protocol, a gauge appears showing you the progress of the transmission; you will not see the actual text appear on your screen.

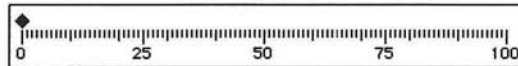

You can stop a transmission by holding down the Command key and then pressing the period (.) key.

The Eject button ejects the disk named in the dialog box. If you have two drives with a disk in each and eject a disk from one, MacTerminal automatically switches to the disk in the other drive and shows its name and appropriate files in the dialog box. If you insert a disk again into the empty drive, MacTerminal switches back to that disk.

The Drive button lets you switch between drives when you have more than one drive with a disk inside.

Receive File

Prepares MacTerminal to receive a file sent with the MacBinary, XModem Text, or Straight XModem protocols. With these File Transfer protocols, you must choose Receive File from the File menu, and name the file.

Make sure that the disk or folder named in the dialog box is the one you want this file to be saved on. If not, use Drive and Eject to switch to other disks and folders.

When you see the right disk's name in the dialog box, name the incoming file in the space provided. Click Receive, or press the Return key. If a file already exists with that name on the disk, you're asked to confirm that you want the new file to replace the existing one.

After you click the Receive button, MacTerminal waits approximately 1½ minutes to receive the file. If you're communicating by modem, you choose Wait For Call. When the other computer calls and starts to send the file, a gauge indicates the progress of the transmission. MacTerminal receives the file and sends it immediately to a disk; the file does not appear in the terminal display area. When you quit MacTerminal, the file with the name you specified will be on the disk you specified.

The command is dimmed unless you have checked MacBinary, XModem Text, or Straight XModem as the File Transfer protocol you want, in the File Transfer dialog box from the Settings menu.

File Name: <input type="text" value="Price"/>	Terminal
<input type="button" value="Receive"/> <input type="button" value="Cancel"/>	<input type="button" value="Eject"/> <input type="button" value="Drive"/>

Page Setup

Lets you specify the size of paper you'll be printing your document on; whether it will be printed across the width of the page or sideways across its length; whether or not to divide the text into pages; and whether or not to reduce the size of the type.

A dialog box presents the various options. For example, to print data that is 132 character-columns wide, check US Legal and Wide to print across the length of an 8½- by 14-inch page. You can print up to about column 124 across the length of 8½- by 11-inch paper. The preset options are checked as follows:

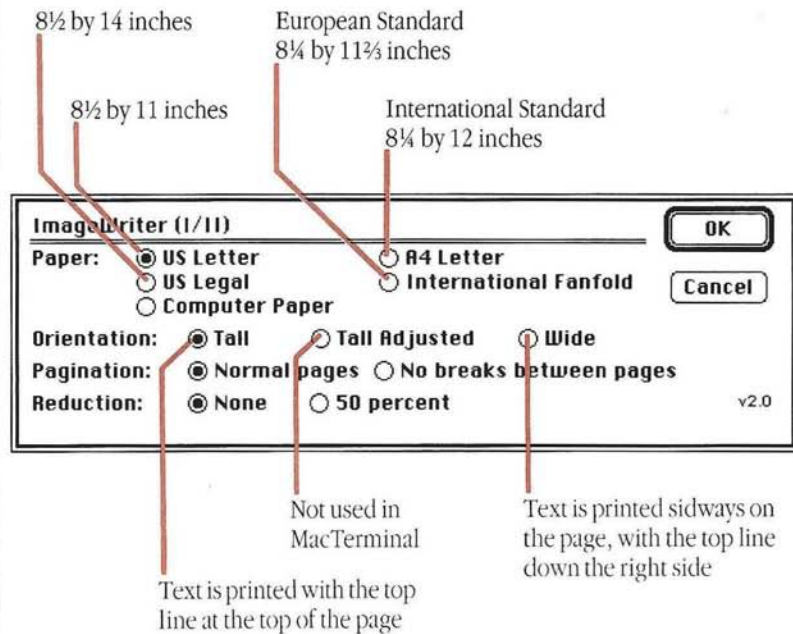

The Tall Adjusted option isn't used with MacTerminal. In other Macintosh applications, you use it to print correctly proportioned geometric figures.

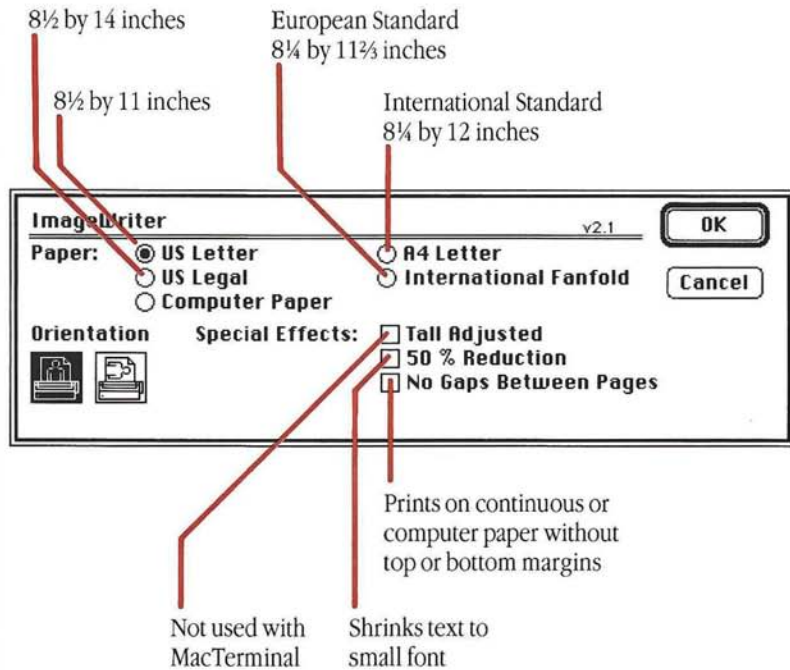

Print Selection

Prints what is selected in the MacTerminal document. A dialog box presents the various options with the preset ones checked as follows:

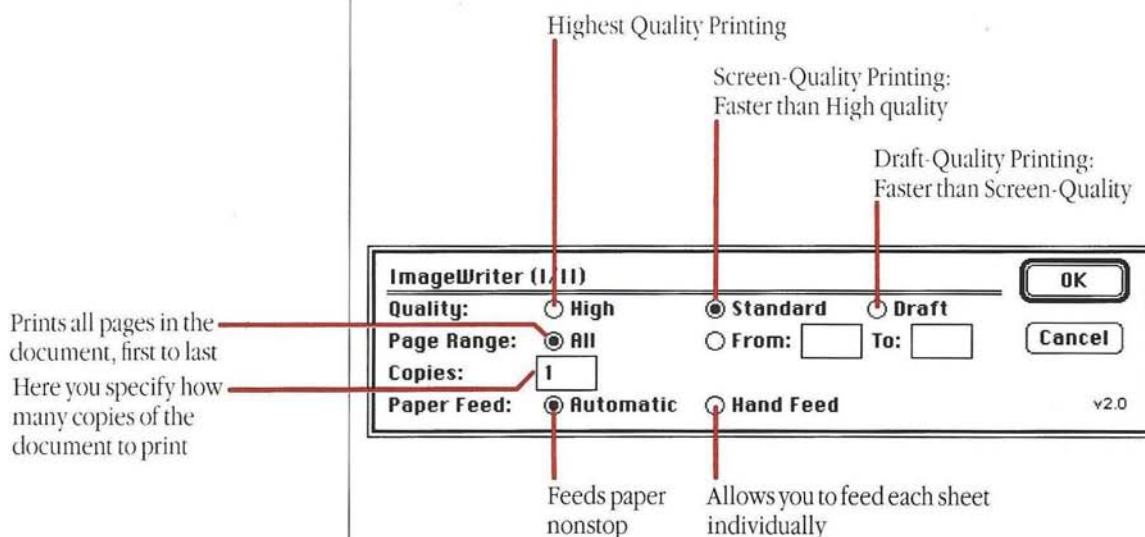

To stop printing, hold down the Command key and press the period (.) key.

Quit

Closes the MacTerminal document, if open, and returns you to the Finder. If the document is untitled, you're given the opportunity to name and save it. Or, if you've changed settings or other information in the menu commands since last saving the document, you're given the opportunity to save the changes. See "Save As," earlier in this chapter, for more information about saving settings and data.

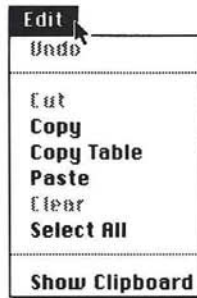

Undo

Undoes the effects of your most recent action. In MacTerminal, you can choose Undo only when working with desk accessories. Undo is dimmed when a MacTerminal document window is active.

Cut

Removes a selection from a desk accessory and places it on the Clipboard, replacing the Clipboard's contents, if any. You can't cut data from a MacTerminal document. You can only copy a selection to place it on the Clipboard. (Copy and Copy Table are described next). Cut is dimmed when a MacTerminal document window is active.

Copy

Copies a selection from a MacTerminal document or a desk accessory and places it on the Clipboard, replacing the Clipboard's contents, if any. You can use Copy to copy any selected text; however, if you're copying tables, choose Copy Table.

Copy Table

Copies a table selected from a MacTerminal document and places it on the Clipboard, replacing the Clipboard's contents, if any. Copy Table transforms the spaces between two columns into tabs so that data remains in columns when you paste a table into certain spreadsheet applications that require tabs to set up columns. Some Macintosh spreadsheet applications, like Microsoft Excel, will paste a table in its proper format only if the table has tab characters separating the columns. Use Copy Table for this type of application.

Paste

Sends the text in the Clipboard to the other computer when you paste it in a MacTerminal document. If you paste something into your document, and do not see anything on the screen, the other computer may not be “echoing” back whatever you send; in this case, to see what you’re pasting, go to the Settings menu, choose Terminal, and click Local Echo. (Remember that by itself Local Echo does not send anything.) In desk accessories that accept text, Paste replaces the current selection with the contents of the Clipboard or inserts the contents at the insertion point or in the space available.

Clear

Removes a text selection from a desk accessory without placing it on the Clipboard. Clear is dimmed when the MacTerminal document window is active.

Select All

Selects all data currently in the MacTerminal document. Select All is dimmed if the MacTerminal window is not active. To turn off the selection, click anywhere within the document.

Show Clipboard/Hide Clipboard

Show Clipboard displays the contents of the Clipboard (what you most recently cut or copied). When the Clipboard window is open, this command changes to Hide Clipboard.

Commands Menu

The Commands menu contains commands that affect the operation of MacTerminal while you’re in a communications session. You’ll choose some of these commands as a response to a situation created by the other computer.



Record Lines Off Top/Don't Record Lines Off Top

The preset option is Record Lines Off Top. When Record Lines Off Top is chosen, its alternate, Don't Record Lines Off Top, shows.

- Record Lines Off Top—MacTerminal records lines of data in the open document and automatically saves them to the copy of the document stored on the disk as the lines scroll off the top of the terminal display area (or off the top of a shorter scrolling area defined by the other computer's application). If you haven't named and saved the document, MacTerminal stores the data in a temporary file until you save the document. You can choose this command in the middle of a session, to record only the interesting part. If you are receiving information from a mainframe application that sends one screen of information at a time and clears it without scrolling up, you must also go to the Settings menu, choose File Transfer, and then choose Save Screens Before Clearing. Otherwise, screens full of data get lost.
- Don't Record Lines Off Top—MacTerminal stops recording data in the document and saving it to the disk. This command does not erase data that has already been recorded.

When recording lines or saving screens, MacTerminal saves the data to disk. When that disk becomes full in the middle of a session, MacTerminal turns off the Record Lines Off Top command and stops saving the information to the disk. To save the rest of your session, go to the File menu and choose Save As. Eject the current disk, insert another, and click Save. Turn Record Lines Off Top back on again. Incoming data will be saved to the document on the new disk.

Clear Lines Off Top

Erases the data that MacTerminal has recorded off the top of the terminal display area (or off the top of a shorter scrolling area defined by the other computer's application). At the same time, MacTerminal erases the same data from the document on the disk. A message appears that asks you to confirm the command. If you are sure of what you're doing, you can avoid the confirming message by holding down the Option key while you're choosing the command.

Reset

Erases the data in the terminal display area and returns the settings you changed during a communications session to the way they were when you opened or last saved the MacTerminal document. This command has the same effect as a reset command sent from a host computer. A message appears that asks you to confirm the command. If you are sure of what you're doing, you can avoid the confirming message by holding down the Option key while you choose the command.

Start Scrolling/Stop Scrolling

The preset option is Start Scrolling. When Start Scrolling is chosen, its alternate, Stop Scrolling, shows.

Stop Scrolling stops the display of incoming data; Start Scrolling starts it again. Stop Scrolling and Start Scrolling are equivalent to the VT100 Control-S and Control-Q sequences that interrupt and resume the display of data on the screen. These commands are dimmed unless the Handshake protocol XOn/XOff is checked in the Compatibility dialog box in the Settings menu.

Unlock Keyboard

Enables MacTerminal to resume sending data. Use this command when the remote computer has sent an XOff command and “locked” MacTerminal’s keyboard. With MacTerminal, a locked keyboard prevents you from issuing any commands from the keyboard except Control-S (to tell the other computer to stop sending data). Unlock Keyboard is dimmed unless the keyboard is locked.

The Status Lights option for the VT100 terminal type (Settings menu: Terminal) shows the status of the keyboard. When you see the Kbd Locked indicator “light” turned on, the other computer has locked the keyboard.

Settings Menu



The Settings menu contains commands that present the options you need to set up MacTerminal to communicate with the other computer.

Terminal Settings

The Terminal command options allow you to designate the type of terminal MacTerminal emulates and to choose some terminal features. Choosing this command shows a dialog box listing the options; click to choose the ones you want. Choosing a terminal type dims those options that won't work with the terminal you've chosen.

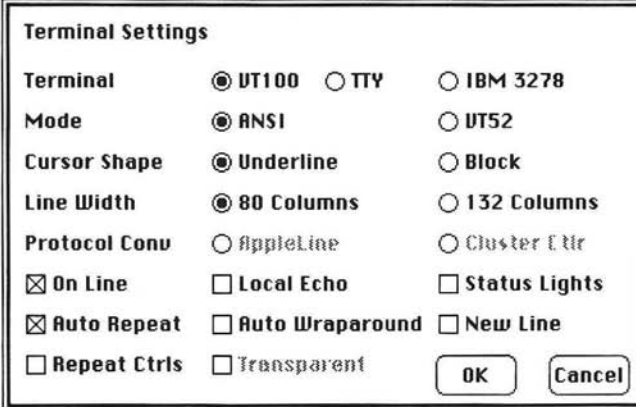

The image shows a dialog box titled "Terminal Settings". It contains several rows of options, each with a label and one or more radio or checkbox controls. The options are: Terminal (radio buttons for VT100, TTY, IBM 3278), Mode (radio buttons for ANSI, VT52), Cursor Shape (radio buttons for Underline, Block), Line Width (radio buttons for 80 Columns, 132 Columns), Protocol Conv (radio buttons for AppleLine, Cluster Ctrl), On Line (checkbox), Local Echo (checkbox), Status Lights (checkbox), Auto Repeat (checkbox), Auto Wraparound (checkbox), New Line (checkbox), Repeat Ctrls (checkbox), and Transparent (checkbox). At the bottom right are "OK" and "Cancel" buttons.

Terminal	<input checked="" type="radio"/> VT100	<input type="radio"/> TTY	<input type="radio"/> IBM 3278
Mode	<input checked="" type="radio"/> ANSI	<input type="radio"/> VT52	
Cursor Shape	<input checked="" type="radio"/> Underline	<input type="radio"/> Block	
Line Width	<input checked="" type="radio"/> 80 Columns	<input type="radio"/> 132 Columns	
Protocol Conv	<input type="radio"/> AppleLine	<input type="radio"/> Cluster Ctrl	
<input checked="" type="checkbox"/> On Line	<input type="checkbox"/> Local Echo	<input type="checkbox"/> Status Lights	
<input checked="" type="checkbox"/> Auto Repeat	<input type="checkbox"/> Auto Wraparound	<input type="checkbox"/> New Line	
<input type="checkbox"/> Repeat Ctrls	<input type="checkbox"/> Transparent	<input type="button" value="OK"/>	<input type="button" value="Cancel"/>

Terminal

The preset option for a new document is VT100.

- VT100—MacTerminal emulates the DEC VT100.
- TTY—MacTerminal emulates the standard Teletype terminal, which ignores many commands from the remote computer that the VT100 can respond to. The TTY (Teletype) responds to Return, Tab, Backspace, and Line Feed characters and ignores other control characters and all escape sequences.
- IBM 3278—MacTerminal emulates an IBM 3278 terminal linked to an IBM mainframe through the AppleLine or an Apple Cluster Controller.

Mode

The preset option is ANSI.

You have a choice of modes only if you are emulating a VT100. The VT52 is an older model of the VT100.

Cursor Shape

The preset option is Underline.

- Underline—The cursor is a blinking underscore.
- Block—The cursor is a blinking solid rectangle.

Line Width

The preset option is 80 columns.

MacTerminal's display area can be 80 or 132 columns wide by 24 lines long. A column is equal to one character in the Macintosh 9-point Monaco font, the font MacTerminal uses as the basis for its own custom font.

Changing the line width erases the terminal display area and returns the cursor to the top left of the screen.

Use the horizontal scroll bar to scroll to the 132nd column.

Protocol Conv

The preset option is AppleLine. Protocol Conv (Converter) applies only to the IBM 3278.

- AppleLine—The Macintosh is attached to an IBM control unit or mainframe through the AppleLine.
- Cluster Ctrl (Controller)—The Macintosh is attached to an IBM control unit or mainframe through an Apple Cluster Controller.

See Appendixes C and D for more information on these two devices.

On Line

The preset option is checked (on).

- Checked (on)—When you start a communications session, MacTerminal is connected to and accessible to the other computer.
- Unchecked (off)—MacTerminal stops communicating with the other computer without terminating the connection (a condition called “off-line”). This allows you to do something else in the terminal display area, in a desk accessory, or in another application. MacTerminal displays all the characters you type. Checking the option resumes communication with the remote computer.

The Status Lights option for the VT100 terminal type shows whether On Line is checked or not (see “Status Lights,” below).

Local Echo

The preset option is unchecked (off).

- Checked (on)—All characters you type on the keyboard or numeric keypad (or select from the Keypad menu, described in “Keypad Menu,” later in this chapter) are displayed locally by MacTerminal. Check Local Echo when the other computer specifies half duplex in its communications parameters (that is, when the other computer does not echo back your keystrokes).
- Unchecked (off)—MacTerminal does not display characters as you send them. If you are sending or receiving in Full Duplex, all characters you type on the keyboard or numeric keypad (or select from the Keypad menu) are echoed back by the other computer rather than by MacTerminal. Turn Local Echo off when the other computer specifies full duplex in its communications parameters (that is, when it echoes back your keystrokes).

The Status Lights option for the VT100 terminal type shows you whether Local Echo, displayed as “Local,” is checked or not. (The Status Lights option is described next.)

Status Lights

The preset option is unchecked (off). Status Lights applies only to the DEC VT100.

- Checked (on)—MacTerminal displays a panel of status lights like those on a DEC VT100 terminal. The panel is displayed at the top of the document window under the title bar.
- Unchecked (off)—MacTerminal does not display the DEC VT100 status lights.

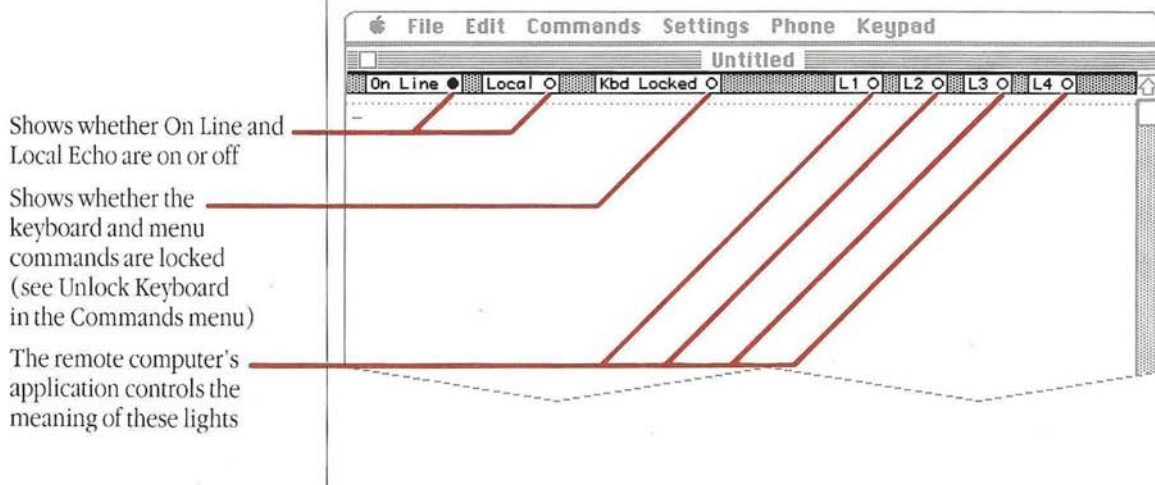

Auto Repeat

The preset option is checked (on).

- Checked (on)—A character repeats when you hold down a character key. The Repeat Ctrl's option must be checked also for control keys, such as the Tab, Return, and Backspace keys, to repeat. You can specify the rate of repeat with the Control Panel in the Apple menu.
- Unchecked (off)—Characters don't repeat when you hold down a character key.

Auto Wraparound

The preset option is unchecked (off).

The Auto Wraparound option affects the appearance of incoming text in MacTerminal's terminal display area.

- Checked (on)—When the cursor reaches the 81st or 133rd column, MacTerminal automatically returns it to the first column. Uncheck this option if the other computer provides this feature. You usually use the Auto Wraparound feature with the New Line option described next.
- Unchecked (off)—When the cursor reaches the 81st or 133rd column, the cursor stops, and incoming characters write over the last character on the line.

New Line

The preset option is unchecked (off).

- Checked (on)—When MacTerminal receives a Line Feed character from the other computer, the cursor moves to the first position on the next line. When you press Return, MacTerminal sends both a Return and a Line Feed character. Use this option when incoming data does not move down to the beginning of the next line.
- Unchecked (off)—When MacTerminal receives a Line Feed character from the other computer, the cursor moves down one line and stays in the same column. When you press Return, MacTerminal sends only a Return character, which moves the cursor to the first position on the same line.

Repeat Ctrl's

The preset option is unchecked (off). Repeat Ctrl's (Controls) is dimmed unless Auto Repeat is checked.

- Checked (on)—A control character repeats when you hold the character key down. Control characters are Tab, Return, Backspace, and all keys pressed with the Command key.
- Unchecked (off)—A control character doesn't repeat when you hold down the character key.

Transparent

The preset option is unchecked (off). Transparent applies only to the TTY.

- Checked (on)—Control characters appear as sequences of two or three characters in the terminal display area. Control characters don't function when they're displayed.
- Unchecked (off)—Control characters are not displayed as characters but instead have their normal effect in the terminal display area.

Compatibility Settings

The Compatibility command options allow you to set up MacTerminal to communicate with the other computer so that data is sent and received with a minimum of error. MacTerminal and the other computer must be set with the same communications parameters.

Compatibility Settings



Baud Rate 50 75 110 134.5
 150 200 300 600
 1200 1800 2000 2400
 3600 4800 9600 19200

Bits per Character 7 Bits 8 Bits

Parity Even Odd None

Handshake HOn/HOff None

Connection Modem Another Computer

Connection Port  

Baud Rate

The preset option is 1200.

The baud rate is the speed at which data passes to and from the remote computer—usually the number of bits sent per second. MacTerminal and the remote computer must transmit at the same speed. Most modems transmit at 300 or 1200 baud over telephone lines. You usually use the other speeds for transmitting to a computer that is directly connected by cable.

Garbled incoming data, or no data at all, can sometimes mean the baud rate set for MacTerminal doesn't match the other computer's.

Bits per Character

The preset option is 8 bits.

This option refers to the number of bits that comprise a character. MacTerminal can send and receive 7-bit or 8-bit characters, whichever the other computer requires. Some computers require a “start or stop bit” setting; MacTerminal sets these automatically when you set Bits per Character.

Parity

The preset option is None.

Parity refers to the way MacTerminal and the remote computer check that data isn't garbled in transmission. MacTerminal has three parity options: Even, Odd, and None. MacTerminal does not have mark parity or space parity.

Parity errors are printed as rectangular boxes.

Handshake

The preset option is None.

The Handshake protocol is often called the XOn/XOff protocol. The other computer must support the Handshake protocol for you to use it.

- XOn/XOff—Regulates the flow of data between the Macintosh and the other computer. Using XOn/XOff prevents the loss of data when either MacTerminal or the other computer sends characters faster than the other can receive them. Usually you won't need to use XOn/XOff for a baud rate of 1200 or slower. However, some commercial services, such as MCI Mail, require Handshake for controlling data flow.

XOn/XOff lets you use Start Scrolling or Stop Scrolling in the Commands menu.

- None—MacTerminal doesn't regulate the flow of data from the other computer, nor does MacTerminal respond to the other computer's attempts to regulate the flow of data from MacTerminal (MacTerminal ignores XOn/XOff sent by the other computer.) If the remote computer sends information faster than MacTerminal can receive it, characters will be missing from incoming data. You can try a slower baud rate if the Macintosh is directly connected to the other computer. Or try using Don't Record Lines Off Top from the Commands menu to speed up MacTerminal's ability to process incoming data.

You'll usually want to use the Handshake protocol for baud rates over 1200 if the other computer supports the protocol.

Connection

The preset option is Modem.

- Modem—MacTerminal communicates with the other computer through a modem. The Modem option activates the Phone menu.
- Another Computer—MacTerminal communicates with the other computer through a cable or tie line attached to another computer.

Connection Port

The preset option is the Modem port.

The Connection Port options specify which port on the back of the Macintosh you're using to attach the cable to the modem or the other computer. The option icons are the same as those that identify the ports on the back of the Macintosh.

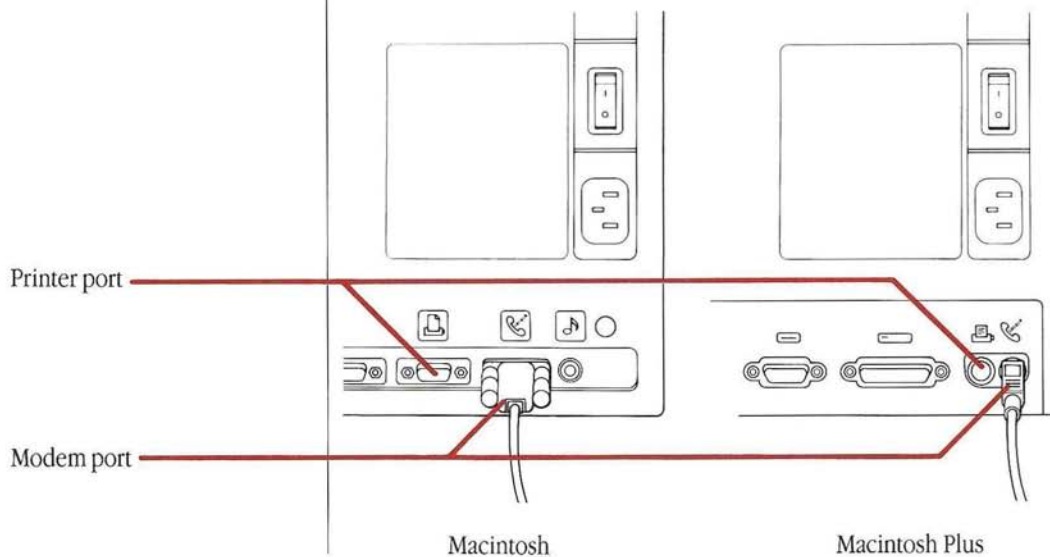

Although you can use either the Printer port or the Modem port, the Modem port is usually recommended for sending data to another computer, whether MacTerminal is sending through a modem or a direct tie line. Some hard disks are designed to be connected to the Modem port, in which case you must use the Printer port to connect your modem or tie line. In this case only, use the Hard Disk document to open a session. The Apple Hard Disk 20 connects to the External Disk drive port, leaving the Modem port free.

The Printer port works well for data transmitted at speeds up to and including 1200 baud. If you're sending data at speeds faster than 1200 baud, you may lose some data in the transmission depending on the type of hard disk you have connected to the Modem port. Check with your authorized Apple dealer or the hard disk manufacturer for information on using the hard disk with MacTerminal. Also, see "Using MacTerminal With a Hard Disk," later in this chapter, for more information on using MacTerminal with a hard disk drive.

File Transfer Settings

The File Transfer options let you set up MacTerminal in various ways to send and receive data.

File Transfer Settings

Settings for Pasting or Sending Text:	File Transfer Protocol
Delay Between Chars <input type="text" value="0"/> 60ths Second	<input checked="" type="radio"/> Text
Delay Between Lines <input type="text" value="0"/> 60ths Second	<input type="radio"/> MacBinary
<input checked="" type="checkbox"/> Word Wrap Outgoing Text	<input type="radio"/> HModem Text
Settings for saving lines off top:	<input type="radio"/> MacTerminal 1.1
<input checked="" type="checkbox"/> Retain Line Breaks	<input type="radio"/> Straight HModem
<input type="checkbox"/> Save Screens Before Clearing	<input type="button" value="OK"/> <input type="button" value="Cancel"/>

Settings for Pasting or Sending Text

These options let you adapt the speed and format of what you send, to accommodate the other computer.

Delay Between Chars and Delay Between Lines

The preset option for each is none.

These options let you specify a delay between characters or lines being sent to another computer that can't receive data as fast as the Macintosh is sending it. You use this option when you can't adjust the baud rate. You're likely to use this option when communicating with a private computer system, rather than a large public information service. Try experimenting with the delays until you find a setting that works. Start by setting a delay between lines and then try a delay between characters.

Word Wrap Outgoing Text

The preset option is checked (on).

Word Wrap Outgoing Text applies only to sending text files or pasting (sending) text into a MacTerminal document.

- Checked (on)—At the end of the line (an 80- or 132-column line, depending on the Line Width option that's set), the cursor and the last word that won't fit wrap to the beginning of the next line: MacTerminal will break the line between words rather than between characters. A word is any group of characters separated from other characters by at least one space.

If you've inserted Returns in the text to create narrower margins, the line breaks where you inserted the Return. This option only affects lines that have a return before the 80th column (or 132nd column).

- Unchecked (off)—After the last character in the line, the cursor and the following character move to the next line.

Settings for Saving Lines Off Top

These options let you define what information to save, and how to format the line breaks.

Retain Line Breaks

The preset option is checked (on).

- Checked (on)—MacTerminal records the Return character (at the end of each line sent) from the other computer when MacTerminal records data.
- Unchecked (off)—MacTerminal does not record the Return character.

You use this feature in conjunction with Record Lines Off Top (Commands menu). When you set MacTerminal to record incoming data, you can have it retain or remove the Return character as it's recording the data. Your choice depends on how the other Macintosh application uses the Return character to define the format of text. MacWrite, for example, uses a Return to define a paragraph. If you copy a paragraph to MacWrite from MacTerminal and if the paragraph has a Return character at the end of each line, MacWrite will treat each line as a separate paragraph.

Save Screens Before Clearing

The preset option is unchecked (off).

- Checked (on)—MacTerminal saves the contents of each screen full of information before clearing the screen.
- Unchecked (off)—MacTerminal does not save the contents of the screen; it just clears the screen.

Use this feature when you are communicating with a mainframe application that sends a screen full of information, then clears it, without scrolling. To save the screens, you must also have turned on the Record Lines Off Top option on the Commands menu.

To browse through the material you save, use the scroll bar. Click in the gray part of the scroll bar above the scroll box to see one screen at a time.

File Transfer Protocols

The preset option is Text.

Each protocol represents an agreement between two computers about how they will exchange data.

- Text—MacTerminal sends and receives the file as a sequence of ASCII characters, without any information about format or font. When you choose the Text protocol, and then choose Send File on the File menu, MacTerminal provides you with a list of text files—only. Many Macintosh applications give you the option of saving a document as a text file. For example, MacWrite has a Text Only button in its Save As command, and Multiplan has a SYLK button. Some applications' documents are automatically saved as text files. Use Text when emulating an IBM 3278, or when the other computer can receive only ASCII files and does not support any of the other protocols.
- MacBinary—Use this method to transfer any Macintosh file (a document, an application, or a system file) to or from any computer that supports a protocol called XModem. The XModem protocol, based on a method developed by Ward Christensen, is an agreement to send data and keep on sending data until it gets there; it checks for errors, to make sure your file arrives intact. You can use MacBinary to transfer files from one Macintosh to another, but before you receive a file this way, you must use the Receive File option in the File menu.

In general, use MacTerminal 1.1 to transfer files between Macintoshes; use MacBinary to send a file to an information service, so another Macintosh can pull it back and use it.

- XModem Text—Use with computers that support the XModem protocol, but do not understand the formatting information in a Macintosh file. Unlike mere Text transfer, this method checks for errors. And it keeps your paragraphs intact, adding a line feed signal after each Return so that the other computer moves down to the next line before starting the next line of text. When you are receiving text with this method, the Macintosh strips those line feeds out.
- MacTerminal 1.1—Use this method to transfer any type of file between two Macintoshes. The Macintosh document that comes with your MacTerminal disk is already set to this option. If you want to receive a file later, and can't be at the computer to enter the necessary commands, use MacTerminal 1.1, then choose Wait For Call on the Phone menu.
- Straight XModem—For programmers only. Use this method to transfer the data portion of a file to another computer that supports the XModem protocol.

Answerback Message

Presents a dialog box in which you specify a message identifying MacTerminal to another computer (usually a host computer) that requires it. The other computer specifies what the message must be. You may need to send an answerback message when you're communicating with certain types of private computer systems. Most public information services don't require it.

The message can be comprised of any series of characters up to 40. Some answerback messages require a control character—for example, the control character ^M designates a Return character. You type the control character by using the Shift key to type the caret (^) above the number 6 key on the main keyboard and then typing the appropriate letter.

If you've already entered an answerback message, it appears selected (highlighted), and you can replace it by typing another.

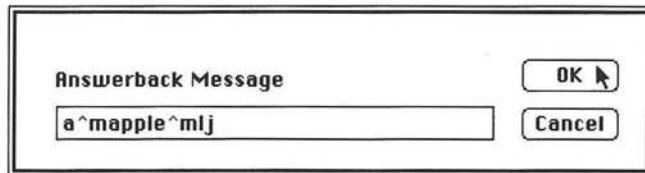

You can also use the answerback message when you're communicating with another Macintosh or other personal computer. It's a convenient way to let the other computer know that you've made contact.

When communicating with a large computer system, MacTerminal sends the message you've specified when the other computer requests it. Or you can send it yourself.

- Control-Enter sends the answerback message: Hold down Control (the Command key) and press Enter. MacTerminal sends the message.
- Control-E asks for the message: Hold down Control and press E. The computer at the other end automatically sends its answerback message.

Character Sets

Instead of the normal complement of Macintosh fonts, MacTerminal has two built-in sets of characters it can display on its screen: G0, the primary set, and G1, the alternate set. The Character Sets command lets you choose between the two sets, as well as specify each set from a collection of standard, special, and foreign character sets. You'll usually use only the character set appropriate for your country and language; you might, however, need the Graphics character set to do on-screen graphics, or a German character set to communicate to a multilingual mainframe.

Character Set Settings

Currently Active: G0 G1

G0 Character Set:

<input type="radio"/> Graphics	<input checked="" type="radio"/> US Ascii	<input type="radio"/> UK Ascii	<input type="radio"/> Norwegian
<input type="radio"/> French	<input type="radio"/> Spanish	<input type="radio"/> German	<input type="radio"/> Danish
<input type="radio"/> French-Canadian	<input type="radio"/> Italian	<input type="radio"/> Swed. Finn. E47	
<input type="radio"/> Alt. ROM Graphics	<input type="radio"/> Alt. ROM	<input type="radio"/> Swed. Finn. D47	

G1 Character Set:

<input type="radio"/> Graphics	<input checked="" type="radio"/> US Ascii	<input type="radio"/> UK Ascii	<input type="radio"/> Norwegian
<input type="radio"/> French	<input type="radio"/> Spanish	<input type="radio"/> German	<input type="radio"/> Danish
<input type="radio"/> French-Canadian	<input type="radio"/> Italian	<input type="radio"/> Swed. Finn. E47	
<input type="radio"/> Alt. ROM Graphics	<input type="radio"/> Alt. ROM	<input type="radio"/> Swed. Finn. D47	

Note that the optional character sets normally available on the Macintosh with the Option key (and seen with the Key Caps desk accessory) are not usable in MacTerminal.

Currently Active

The preset option is G0, which is VT100 talk for primary.

MacTerminal can display characters from two character sets simultaneously, although you can receive (or type) characters in only one set at a time.

The Currently Active setting lets you control which character set incoming (or typed) characters will be shown in.

G0 Character Set

The preset option is US ASCII.

This set of options lets you choose from among 14 character sets to use for the primary character set.

- US ASCII—The standard set of letters, numbers, and symbols used in North American English computers.
- UK ASCII—The same as US ASCII but with the pound sterling symbol (£) instead of the number sign (#).
- Graphics—The set of graphics characters used to create line drawings on a VT100 terminal.
- Norwegian, French, Spanish, German, Danish, French-Canadian, Italian, Swedish/Finnish E47 and D47—Various character sets with accented characters. Note that the keyboard layout for these character sets follows the DEC standard and may be different from the Macintosh keyboard layout for that country.
- Alternate ROM Graphics and Alternate ROM—character sets used in special versions of the VT100 terminal.

G1 Character Set

The preset option is US ASCII.

This set of options lets you choose from among 14 character sets to use for the alternate character set. The choices for Alternate Character Set are the same as the choices for Primary Character Set, above.

Keyboard Configuration

The preset option is that pressing Backspace alone yields backspace; pressing Command-backspace yields delete.

You can choose to have the Backspace key work as a Delete key or as a Backspace key. Command-Backspace gives you the alternate function.

Keyboard Configuration

Backspace Key

Backspace alone yields backspace; ⌘-backspace yields delete.

Backspace alone yields delete; ⌘-backspace yields backspace.

- The first option means that pressing the Backspace key will simply back you up one space. Pressing the Control key at the same time as the Backspace key will back up one character, and delete it.
- The second option reverses that. Pressing Backspace eats up a character, and moves you to the left; pressing the Control key at the same time as the Backspace key backs you up one character, without deleting it.

Show Tab Ruler/Hide Tab Ruler

The preset option is Hide Tab Ruler. Its alternate, Show Tab Ruler, shows in the menu of a new MacTerminal document.

Show Tab Ruler presents a ruler showing tab markers preset every eight characters, or wherever you set them. A tab marker determines where the cursor moves when MacTerminal receives a tab character from the other computer. The tabs on the tab ruler affect only incoming data. Click under the ruler's scale where you want to add a tab; click on a tab to remove it.

If you know the other computer is sending a table with tab characters separating the columns, you must change the tab ruler *before the table is sent* to change the number or spacing of columns in the table. A sophisticated application on the host computer might set tabs for you.

Most tables that other computers send use spaces rather than tabs to separate the columns. If you copy a table into another application that requires tabs between columns (like Excel), you can change the spaces to tabs by copying the table with the Copy Table command from the Edit menu. You can alter the spacing or number of columns once you've pasted the table into the application. See "Copy Table" earlier in this chapter.

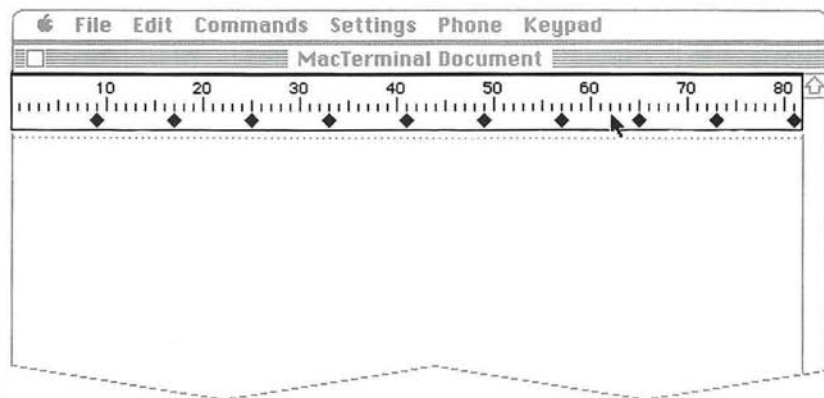

Phone Menu

The Phone menu contains commands for specifying the other computer's phone number, for dialing the number and hanging up, and for receiving a call from another computer. This menu is dimmed unless the Connection option Modem is checked in the Compatibility dialog box (Settings menu). The commands in this menu work with the Apple modems or Apple-compatible modems. If you have another type of modem, you may be able to command your modem from MacTerminal by using the keyboard. Refer to "More About Modems," later in this chapter, for more information.

If you use the Cancel button in each of the dialog boxes associated with the Phone commands, you'll notice that a few seconds elapse before the command is canceled.



Dial

Signals the modem to dial the phone number you entered in the Phone Settings dialog box (Phone menu). A message tells you that MacTerminal is calling, and then tells you whether or not MacTerminal connects.

Hang Up

Signals the modem to terminate the telephone connection. A message tells you that MacTerminal is hanging up.

Wait For Call

Signals the modem to wait for a call from another computer and presents a message telling you that MacTerminal is waiting for a call. When the phone rings, the modem answers it on the third ring unless you have changed the setting in the Phone Settings dialog box (Phone menu). The dialog box disappears as soon as the modem answers the phone.

Phone Settings

The Phone Settings command is dimmed if Another Computer is checked in the Compatibility dialog box (Settings menu).

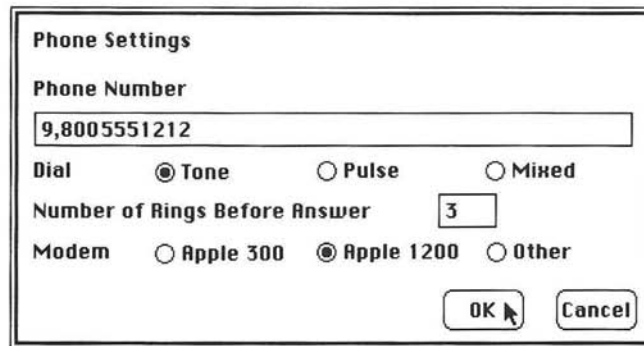

Phone Settings

Phone Number

9,8005551212

Dial **Tone** **Pulse** **Mixed**

Number of Rings Before Answer 3

Modem **Apple 300** **Apple 1200** **Other**

OK Cancel

Phone Number

Allows you to specify the access number for the other computer. If you've already entered a number, it appears selected (highlighted), and you can replace it by typing another.

A comma after a number causes the modem to pause before dialing the remaining numbers. Use a comma when entering a number used to get an outside line or whenever you dial a number and then wait for a dial tone. Refer to your modem manual for further information on giving instructions to your modem.

Dial

The preset option is Tone.

Tone, Pulse, and Mixed are types of transmission signals used by telephone companies. Tone is the most common in use today and is used with most push-button telephones. Pulse is used with many rotary-dial telephones and is still found in parts of the United States. Mixed (a combination of both tone and pulse) is used where a tone system exists within a building but the region still uses a pulse system (or vice versa).

If you have a mixed system in your area, part of the phone number will be tone (usually the part that gets you an outside line—9, for instance), and part will be pulse. When you type the phone number, type an uppercase *T* before the tone numbers and an uppercase *P* before the pulse numbers. For example: T9,P4155551212.

Keypad Menu

Number of Rings Before Answer

The preset option is 3.

This feature lets you specify the number of times you want the telephone to ring before the Apple modem answers (when you use Wait For Call in the Phone menu). You can designate any number of rings between 0 and 255. See your modem manual for details.

Modem

The preset option is Apple 1200.

These options let you specify whether you're using an Apple 300, an Apple 1200, or another type of modem.

The Keypad menu contains keypad layouts for the Macintosh. The keypad that appears depends on which terminal is checked in the Terminal dialog box (Settings menu). If VT100 or TTY is checked, you'll see the Macintosh numeric keypad. If IBM 3278 is checked, you'll see a wide keypad with IBM 3278 function keys.

- The Macintosh numeric keypad provides the cursor keys and some of the function keys for the DEC VT100 terminal. To see the function keys, press the menu title, Keypad.

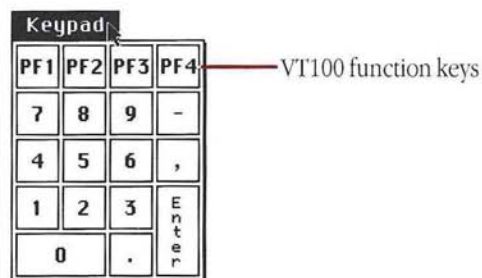

- To see the cursor keys, hold down the Command key to the left of the space bar and press Keypad. Use this keypad if you don't have a Macintosh numeric keypad.

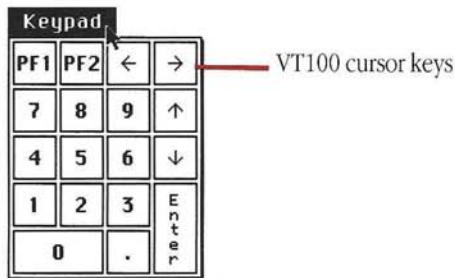

- The other keypad provides the function keys for the IBM 3278 terminal. See “The Macintosh Keyboard” in Appendix C for an explanation of these function keys.

Keypad											
PF1	PF2	PF3	PF4	PF5	PF6	PF7	PF8	PF9	PF10	PF11	PF12
PF13	PF14	PF15	PF16	PF17	PF18	PF19	PF20	PF21	PF22	PF23	PF24
PA1	PA2	Attn	Print	Home	Erase EOF	Delete	Erase Input	Insert	Reset	Sys Req	Clear

Choosing a “key” on any of these menus is like pressing one of the special keys on a VT100 or an IBM 3278 terminal. To choose a key, you position the pointer on the menu title, press the mouse button, drag to the key you want, and release the mouse button.

If you have a numeric keypad, and you are emulating a VT100, the top four keys act as PF keys 1 through 4. To turn /, *, -, and + into the Left-Arrow, Right-Arrow, Up-Arrow, and Down-Arrow keys, hold down the Command key at the same time that you press the key.

If you have a numeric keypad you can use it to duplicate the PF (programmable function) keys on the IBM 3278 terminal. In the diagram, note that there are three levels: you get one set of PF equivalents simply by pressing the key, another by pressing the Command key at the same time as you press the key, and a third by pressing the Option key at the same time as you press the key. When MacTerminal emulates an IBM 3278 terminal, the Return key is equivalent to the New Line key.

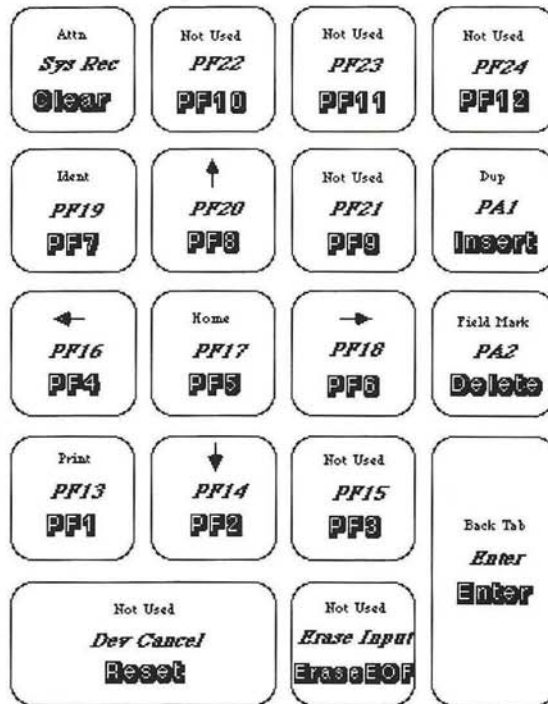

With the Option Key

With the Command Key

Regular Use

Using a Full-Screen Application

Some host computers have applications that use a full screen of data at a time—usually 24 or 25 lines. With some applications, lines of data don't scroll above the terminal display area as you might expect; instead, when you change information in the display, the host computer redisplay the entire screen. With other applications, lines of data scroll (if necessary) to readjust the display whenever you change information.

Full-screen applications take advantage of the DEC VT100 features, particularly the cursor keys that let you move the cursor around on the screen to edit data. MacTerminal uses the Macintosh numeric keypad in the same way and provides you with an equivalent of the numeric keypad in the Keypad menu. You press on the menu title, Keypad, and then drag to the key you want.

- To see the function keys on the numeric keypad, press the Keypad.
- To see the cursor keys, press the Command key and then the Keypad.

In addition to the cursor keys on the numeric keypad, you can use the mouse to position the cursor; position the pointer where you want the cursor to move, and hold down the Option key and click the mouse button. The host computer may move the cursor more slowly than you would like. Be patient. If you click too many times in the same spot, MacTerminal beeps to tell you to stop.

If the host computer's application allows you to position the cursor directly, you can send the cursor to the new position by the most direct, diagonal route. Press Command-Option at the same time that you click the mouse button at your new position.

To avoid overtaxing the host computer, you can also set the speed at which the cursor moves to the new position. On the Settings menu, choose File Transfer, and set the Delay Between Characters at number one. Gradually increase the delay until you reach the speed you want.

More About Modems

Compatible Modems

MacTerminal's Phone menu is designed to be used with Apple modems and Apple-compatible modems, such as the Hayes Smartmodem 1200™, and the U.S. Robotics Autolink™. All of these modems are in the general category of "intelligent" modem—those that can be commanded from the keyboard or, in this case, from communications software like MacTerminal.

Commanding a Modem

Many modems, both compatible and noncompatible, can be commanded to dial and hang up from the keyboard. You can type commands to any intelligent modem and circumvent the Phone menu whenever a MacTerminal document is open and not in a communications session. Refer to your modem manual for the dialing commands to use.

Your Modem and Your Telephone

When your modem is on and you're communicating with another computer, someone calling you will get a busy signal. When your modem is on and you're not in a communications session, and your modem answers the phone before you do, someone calling you will get a high-pitched tone that lasts a few seconds. Your caller may be disconcerted by your modem's greeting, but you can carry on a conversation after that first brief shriek without turning off the modem. If do want to turn it off, be sure you pick up the telephone receiver first, and *then* turn off the modem. If you turn the modem off first, you'll be disconnected.

The Apple Modem 300 and Apple Modem 1200 are set at the factory to answer your telephone after the first ring unless instructed differently. The Apple Personal Modem is set at the factory to answer the phone after zero rings—essentially, not to answer it at all, unless you use the SO command to tell it when to answer. MacTerminal's Phone Settings option Number of Rings Before Answer lets you reset the modem as follows:

- The modem will answer the phone after the number of rings you specify from 0 to 255
- The modem will not answer your phone at all unless you instruct it to "Wait for Call."

The numbers 1 through 255 reset the modem until you turn the modem off. Each time you turn your modem off, you'll need to start MacTerminal in order to let the Number of Rings Before Answer option set the modem with whatever number is specified there.

Using MacTerminal With a Hard Disk

If you are using an Apple Hard Disk 20, attach it to the external disk drive port. You may copy MacTerminal onto the HD20 and run it from there. Do not start with the Hard Disk document, though. That's for people whose hard disk is connected to the Modem port.

If you have a hard disk attached to the Printer port or to the External Disk Drive port, do not use the Hard Disk document for a communications session.

If your hard disk is connected with the Modem port, connect your modem or direct tie line to the Printer port on the back of the Macintosh.

- Don't move your MacTerminal application onto the hard disk.
- Don't open a new document or use any of the preset documents except Hard Disk. Use the Hard Disk document as a template for setting up a communications session. After you've made any necessary changes to the settings and entered the access number, use the Save As command from the File menu to save the document under a different name so you preserve the template and still save your new settings for later use.

The Hard Disk document is preset to communicate through the Printer port. If you open a document that's preset to communicate through the Modem port—as is any new document, or the Commercial Services document—you may damage some data on your hard disk.

The Hard Disk document settings are exactly the same as those for a new document and the Commercial Services document, except for the Port Connection option in the Compatibility dialog box (Settings menu).

Troubleshooting

Most problems you encounter while using MacTerminal are caused by a MacTerminal document whose communications parameters don't match the other computer's. Most problems show up as soon as you start a communications session and begin to send or receive data.

Sometimes you'll have difficulty getting the session started at all. One of the more common problems between personal computers trying to communicate is getting the connection established by modem, particularly between an Apple modem and another type. You and the other person must be sure you both have the correct cables, that the cables and telephone lines are properly plugged in, and that the modem switches are set correctly.

"Noise" or static on the telephone lines is another common problem you'll encounter when communicating by modem to any other computer. Noise can cause garbled data or any number of other problems. There's nothing you can do about noise except to start over and hope the telephone lines behave themselves.

Nothing gets sent or received.

- Make sure all cables are properly connected.
- If you're using a modem, make sure it's on.
- Make sure On Line is checked (Settings menu: Terminal).
- Check that the Baud Rate setting matches the other computer's setting (Settings menu: Compatibility).
- Try changing either Bits per Character or Parity, or both (Settings menu: Compatibility).

Nothing appears on the screen when you send or receive data.

- Check Local Echo (Settings menu: Terminal).
- If you're using MacTerminal 1.1, MacBinary, XModem Text, or Straight XModem protocols (Settings menu, File Transfer), make sure your Terminal type is VT100 (Settings menu: Terminal).
- Make sure both computers are using the same file transfer protocols (Settings menu: File Transfer).

Incoming data is missing random characters.

- Check the XOn/XOff option for Handshake (Settings menu: Communications).
- If the remote computer doesn't support the Handshake protocol and if your Macintosh is directly connected to the other computer, try experimenting with slower baud rates.

If your modem or tie line is connected to the Printer port, you may lose data at baud rates over 1200. Use a file transfer protocol that checks for mistakes (all do except Text) whenever possible.

Incoming data is garbled.

Try changing the communications parameters (Settings menu: Compatibility).

- Make sure the Baud Rate setting matches the other computer's.
- Try changing either Bits per Character or Parity, or both.

Lots of rectangular boxes appear in the incoming data.

Try another parity setting until the transmission is normal (Settings menu: Compatibility).

Incoming data writes over the last character on the first line.

Check Auto Wraparound and New Line (Settings menu: Terminal).

The data appears as double characters.

Uncheck Local Echo (Settings menu: Terminal).

Lines of incoming data are double-spaced.

Uncheck New Line (Settings menu: Terminal).

Incoming data writes over the same line.

Check New Line (Settings menu: Terminal).

Incoming characters disappear off the edge of the screen.

Check Auto Wraparound (Settings menu: Terminal).





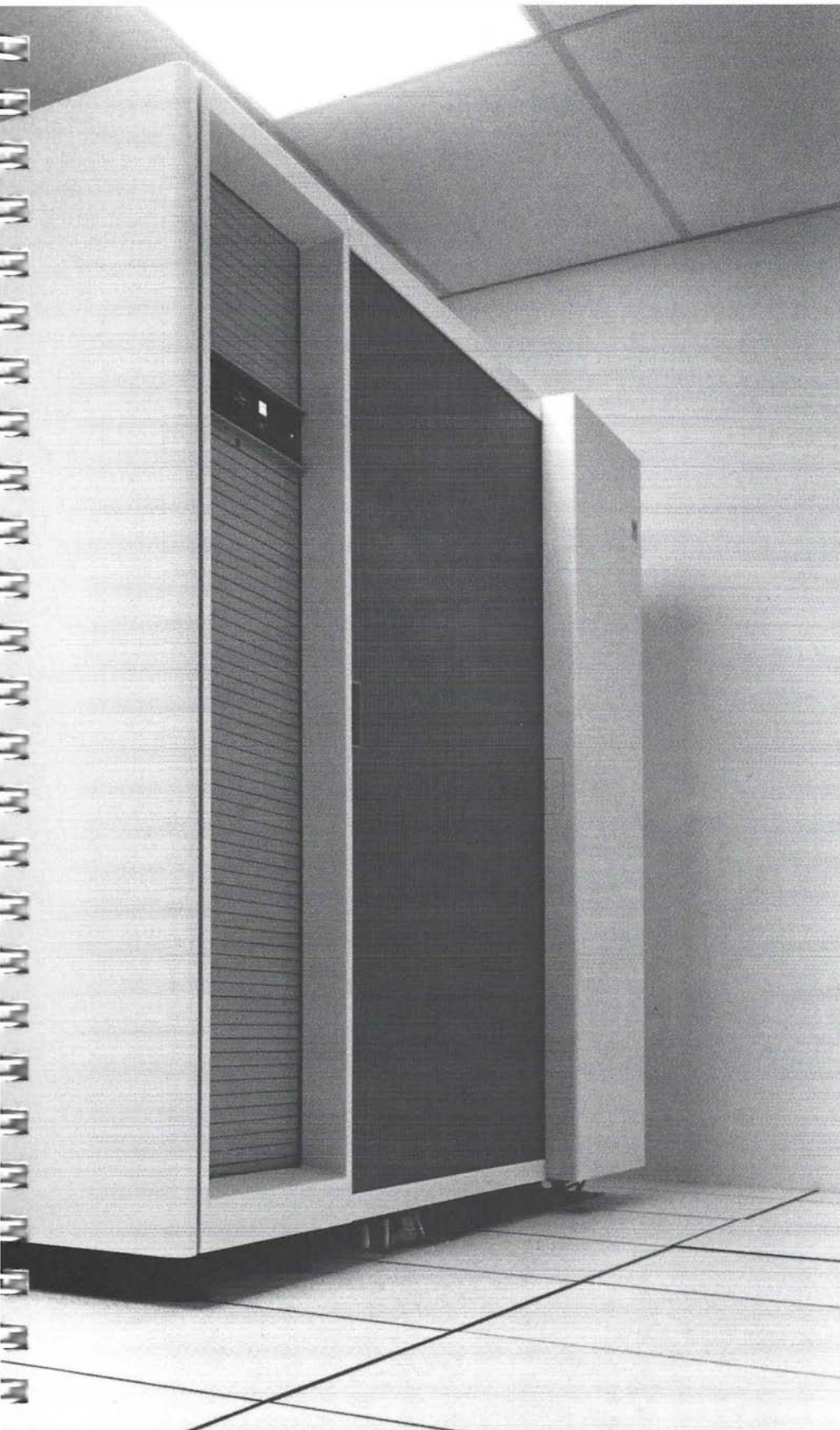

Contents

95	Appendix A: Keyboard Layouts
100	Appendix B: Attaching a Modem to the Printer Port With AppleTalk
101	Appendix C: Installing the AppleLine
115	Appendix D: Installing the Apple Cluster Controller
119	Appendix E: MacTerminal As a DEC VT100
120	Appendix F: ASCII Control Characters
121	Appendix G: Pin Assignments for the Apple Modem Data Cable

Appendix A: Keyboard Layouts

The Macintosh Keyboard

When you are emulating the VT100, MacTerminal redefines three keys on the main Macintosh keyboard to act as the Control key, the Escape key, and the Break key.

- The Command key, located to the left of the space bar, is the Control key.
- The key located in the upper-left corner of the keyboard is the Escape key. To get the grave accent character (˘), hold down the Command key and press the Escape key. To get the tilde (˜), hold down the Command key and the Shift key, and press the Escape key.
- The Enter key functions as the Break key when pressed at the same time as the Option key. Press Option-Enter to send a break to the host computer.
- To send a long break, hold down the Shift key and press Enter.

You can set the way the Backspace key works by choosing Keyboard on the Settings menu. When pressed, the Backspace key can either back up your cursor one space, or delete what it backs up over. You can decide which you feel most comfortable with. The other function is then available when you press the key while holding down Control.

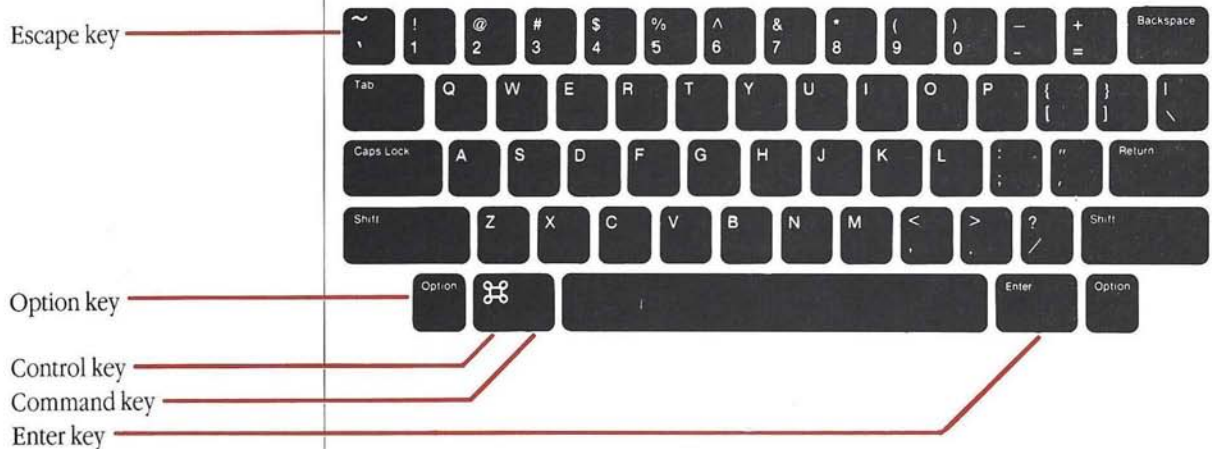

MacTerminal also redefines certain keys on the Macintosh numeric keypad to act like the function keys on the VT100 numeric keypad or IBM 3278. If you have set up your Macintosh to act as a VT100, the Keypad menu provides the equivalent of the VT100 numeric keypad. If you don't have the Macintosh numeric keypad, use the Keypad menu as follows.

- To use the function keys, press on the menu title, Keypad, and drag to the key you want.

Keypad			
PF1	PF2	PF3	PF4
7	8	9	-
4	5	6	,
1	2	3	Enter
0	.		

- To use the cursor keys, hold down the Command key, press Keypad, and drag to the key you want.

Keypad			
PF1	PF2	←	→
7	8	9	↑
4	5	6	↓
1	2	3	Enter
0	.		

If you have a numeric keypad, MacTerminal redefines the keys on the numeric keypad to act like the function keys on the IBM 3278, too. You get one set of PF equivalents simply by pressing the key, another by pressing the Command key at the same time as you press the key, and a third by pressing the Option key at the same time as you press the key. When MacTerminal emulates an IBM 3278 terminal, the Return key is equivalent to the New Line key.

Keypad											
PF 1	PF 2	PF 3	PF 4	PF 5	PF 6	PF 7	PF 8	PF 9	PF 10	PF 11	PF 12
PF 13	PF 14	PF 15	PF 16	PF 17	PF 18	PF 19	PF 20	PF 21	PF 22	PF 23	PF 24
PA1	PA2	Attn	Print	Home	Erase EOF	Delete	Erase Input	Insert	Reset	Sys Req	Clear

If you do not have a numeric keypad, and want to use the IBM-programmable keys, make sure your terminal is set to IBM 3278. Then pull down the Keypad and drag to the key you want. For an explanation of the programmable keys, see Appendix C.

Attn <i>Sys Rec</i> Clear	Not Used <i>PF22</i> PF10	Not Used <i>PF23</i> PF11	Not Used <i>PF24</i> PF12
Ident <i>PF19</i> PF7	↑ <i>PF20</i> PF8	Not Used <i>PF21</i> PF9	Dup <i>PA1</i> Insert
← <i>PF16</i> PF4	Home <i>PF17</i> PF5	→ <i>PF18</i> PF6	Field Mark <i>PA2</i> Delete
Print <i>PF13</i> PF1	↓ <i>PF14</i> PF2	Not Used <i>PF15</i> PF3	Back Tab <i>Enter</i> Enter
Not Used <i>Dev Cancel</i> Reset	Not Used <i>Erase Input</i> Erase EOF		

With the Option Key
With the Command Key
Regular Use

The Macintosh Plus Keyboard

When you are emulating the VT100, MacTerminal redefines three keys on the Macintosh Plus keyboard to act as the Control key, the Escape key, and the Break key.

- The Command key, located to the left of the space bar, is the Control key.
- The key located in the upper-left corner of the keyboard is the Escape key. To get the grave accent character (`), hold down the Command key and press the Escape key. To get the tilde (~), hold down the Command key and the Shift key, and press the Escape key.
- The Enter key functions as the Break key when pressed at the same time as the Option key. Press Option-Enter to send a break to the host computer.
- To send a long break, hold down the Shift key and press Enter.

You can set the way the Backspace key works by choosing Keyboard on the Settings menu. When pressed, the Backspace key can either back up your cursor one space, or delete what it backs up over. You can decide which you feel most comfortable with. The other function is then available when you press the key while holding down Control.



MacTerminal also redefines certain keys on the Macintosh Plus numeric keypad to act like the function keys on the VT100 numeric keypad or IBM 3278.

To use the cursor keys in VT100 mode, hold down the Command key and press the keys in the upper-right corner of your numeric keypad.

The Keypad menu provides the equivalent of the VT100 numeric keypad. If you prefer, you can use the Keypad menu as follows.

- To use the function keys, press on the menu title, Keypad, and drag to the key you want.
- To use the cursor keys, hold down the Command key, press Keypad, and drag to the key you want.

MacTerminal redefines the keys on the numeric keypad to act like the function keys on the IBM 3278, too. You get one set of PF equivalents simply by pressing the key, another by pressing the Command key at the same time as you press the key, and a third by pressing the Option key at the same time as you press the key. When MacTerminal emulates an IBM 3278 terminal, the Return key is equivalent to the New Line key.

For an explanation of programmable keys, see Appendix C.

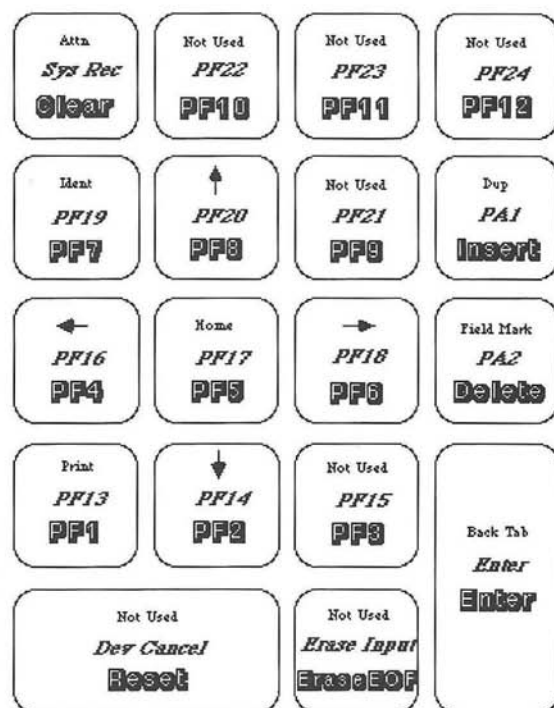

With the Option Key
With the Command Key
Regular Use

Appendix B: Attaching a Modem to the Printer Port With AppleTalk

Where possible, attach your modem to the Modem port. If that is occupied, and you have AppleTalk connected to your Printer port, then you'll need to attach your modem to the Printer port. Here's how:

1. Click AppleTalk Disconnected in the Choose Printer or Chooser desk accessory and select the Printer port.
2. Unplug the AppleTalk connector from the back of your Macintosh. (Never unplug the AppleTalk cables from the connection box; if you do, you'll disable the network.)
3. Connect your modem to the Printer port.
4. Change the setting in the Compatibility dialog box to Printer port.

Do not try to attach AppleTalk connectors to any other port.

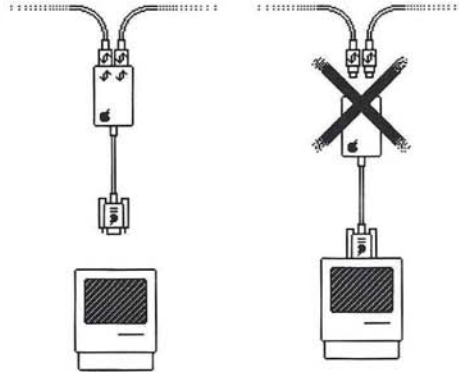

Appendix C: Installing the AppleLine

You'll need the *AppleLine User's Manual* to complete the hookup of the AppleLine to your Macintosh. The following instructions assume that you have already completed the procedures in Chapter 2, Part I, of the *AppleLine User's Manual*, to connect the AppleLine to the IBM system. Before you start using the AppleLine with your Macintosh, you must do three more things:

- Complete the hookup of the AppleLine.
- Set MacTerminal to communicate correctly with the AppleLine.
- Use the AppleLine's supervisor program to enter its passwords and communications parameters.

■ Completing the Hookup

You can connect your Macintosh to the AppleLine directly or through a modem.

It's a good idea to test the system each time you finish connecting a new accessory. Turn on the system to make sure the new part is working.

Direct Connection

To connect your Macintosh directly to the AppleLine, you need a cable assembly that consists of a data cable attached to a gender changer. The assembly is packed with the AppleLine.

The cable assembly has a pin-plug connector at one end and a pin-socket connector (the gender changer) at the other. Here's how to install it:

1. Turn off both the AppleLine and your Macintosh.
2. Attach the pin-plug connector to the Modem port on the back of your Macintosh and tighten the "ear" screws (if any) to secure the connection.

The Modem port is usually recommended for data communications; however, if you have a hard disk connected to the Modem port, you can connect your modem to the Printer port.

3. Attach the pin-socket connector on the gender-changer cable to the connector marked MODEM on the back of your AppleLine, and tighten the ear screws (if any).

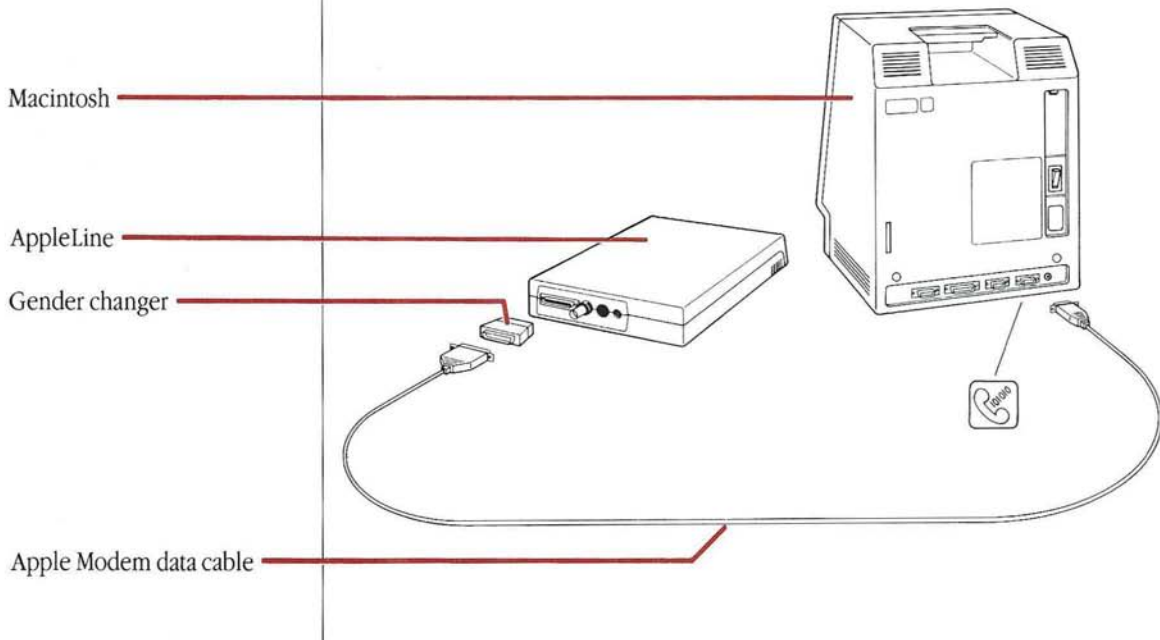

Modem Connection

To communicate with an IBM or IBM-compatible mainframe by modem, you need two Apple modems—one connected at the Macintosh location and another connected to the AppleLine that's connected to the mainframe.

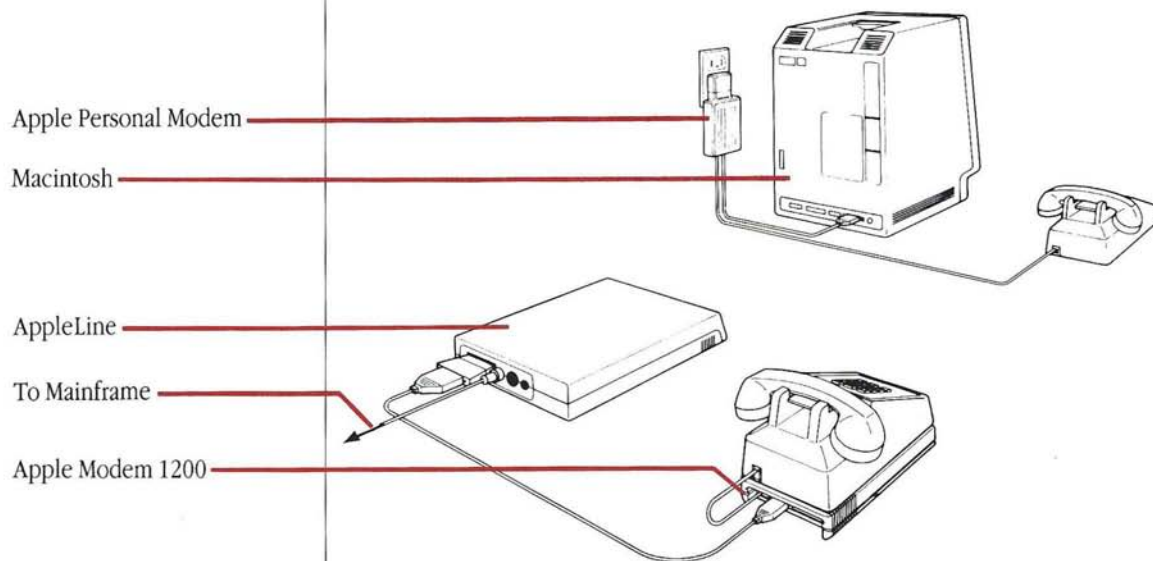

The data cable you need comes packed in the accessory kit with the Apple Modem 300 or Apple Modem 1200. In addition, you need the gender changer that was packed with your AppleLine.

Hook Up the Modem to Your Macintosh

You can use the Apple Modem 300, the Apple Modem 1200, or the Apple Personal Modem.

Hook Up the Modem to the AppleLine

1. Turn off the AppleLine.
2. Plug the gender changer into the connector marked MODEM on the back of your AppleLine.
3. Attach the large connector on the data cable into the gender changer, and tighten the ear screws (if any) to secure the connection.
4. Attach the small connector to the 9-pin socket on the back of the Apple modem and tighten the ear screws (if any).

The MacTerminal disk provides a document named AppleLine that's preset to communicate between your Macintosh and the AppleLine. If you use it and are directly connected to the AppleLine, you don't need to change any settings. If indirectly connected by modem, you may need to reset the Baud Rate (described in step 2). Otherwise, when starting a new document, be sure the settings are as described here.

1. Choose Terminal from the Settings menu.

Set the Terminal options by clicking the circle, the square, or the name of the option you want.

- Terminal Type—IBM 3278

Options that do not apply to the IBM 3278 are dimmed; others that apply are made bold.

- Protocol Conv—AppleLine
- On Line—On
- Auto Repeat—On
- Auto Wraparound—Off
- Repeat Ctrls—Off

The following figure shows the preset options for the Terminal command.

The image shows a dialog box titled "Terminal Settings" with the following options:

Terminal	<input type="radio"/> UT100	<input type="radio"/> TTY	<input checked="" type="radio"/> IBM 3278
Mode	<input checked="" type="radio"/> RNSI	<input type="radio"/> UT52	
Cursor Shape	<input checked="" type="radio"/> Underline	<input type="radio"/> Block	
Line Width	<input checked="" type="radio"/> 80 Columns	<input type="radio"/> 132 Columns	
Protocol Conv	<input checked="" type="radio"/> AppleLine	<input type="radio"/> Cluster Ctrl	
<input checked="" type="checkbox"/> On Line	<input type="checkbox"/> Local Echo	<input type="checkbox"/> Status Lights	
<input checked="" type="checkbox"/> Auto Repeat	<input checked="" type="checkbox"/> Auto Wraparound	<input checked="" type="checkbox"/> New Line	
<input type="checkbox"/> Repeat Ctrls	<input type="checkbox"/> Transparent	<input type="button" value="OK"/>	<input type="button" value="Cancel"/>

2. Choose Compatibility from the Settings menu and set the Compatibility options:

If the Macintosh and the AppleLine are directly connected, set Baud Rate to 9600.

Or

If they are connected through modems, set the baud rate to match the modems. If the modems have different baud rates, set Baud Rate to match the slowest modem. When you change your AppleLine's communications parameters as described in Chapter 3, Part I, of the *AppleLine User's Manual*, set the baud rate to the same speed.

Bits per Character—7 Bits

Parity—Even

Handshake—XOn/XOff

Connection—Another Computer

Connection Port—Modem Port

The following figure shows the preset options for the Compatibility command.

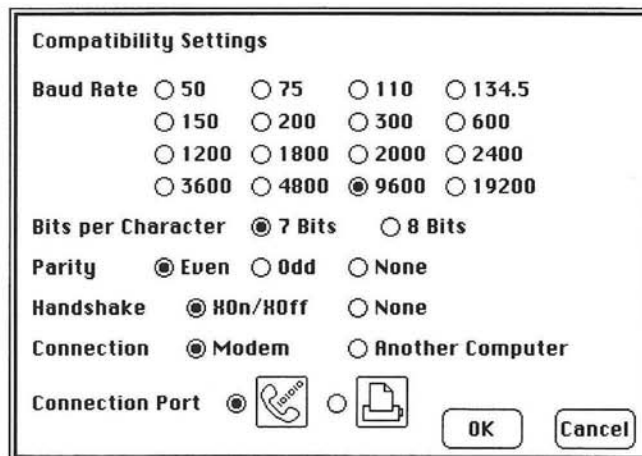

After the AppleLine is hooked up and working, the first thing you should do is enter certain information into its memory. This requires two procedures:

- Send the autobaud message and start the supervisor program, explained below.
- Use the supervisor program described in Chapter 3, Part I, of the *AppleLine User's Manual*.

The first time you use the AppleLine, you use the AppleLine Supervisor document to tell the AppleLine what baud rate your Macintosh is using. You do this by sending the AppleLine a special message that it can analyze to determine the rate.

1. Turn on both your Macintosh and the AppleLine.
2. Start MacTerminal and open the AppleLine Supervisor document. ("Creating a New AppleLine Supervisor Document," later in this appendix, tells you how to set up a new AppleLine Supervisor document if you need to do that.)
3. If you're communicating by modem, choose Phone Settings from the Phone menu and enter the telephone access number to the AppleLine. Set the Dial and Modem features. Then choose Dial from the Phone menu.
4. Once connected and before typing anything else, hold down the Shift key and press the Enter key. Then press Return. You've just sent the autobaud message.

Your AppleLine responds by displaying an identification line across the top of your display area, followed by this message:

.....
Press RETURN to begin the log-on sequence.
.....

5. Press Return.

Your AppleLine will reply with this message:

.....
Enter Password:
.....

6. Type the word *Apples* and then press Return.

This is the preset password to the AppleLine's supervisor program. Your AppleLine replies with this message:

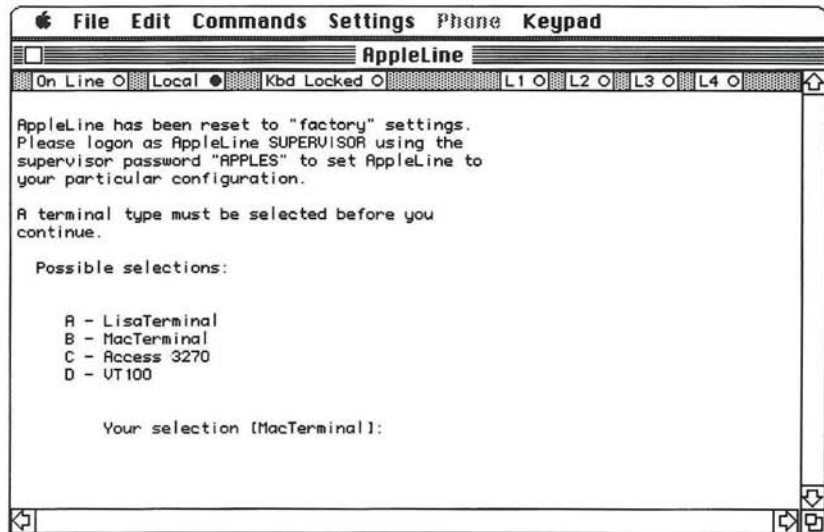

7. Type the letter *B* and then press Return.

This tells the AppleLine that you're using MacTerminal. Your AppleLine replies with this message:

```
.....
Current terminal type is "MacTerminal." Is this correct [Y]?
.....
```

8. Press Return.

Pressing Return accepts the preset response shown inside the brackets (in this case the *Y*, which stands for *yes*). Your AppleLine replies with this message:

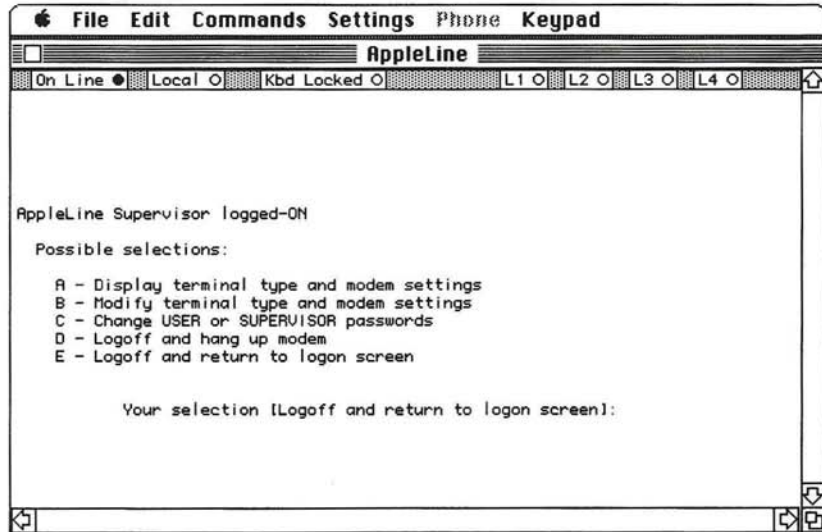

You are now ready to use the AppleLine's supervisor program. Refer to Chapter 3, Part I, of the *AppleLine User's Manual* for a description of what the supervisor program does and how to use it.

Creating a New AppleLine Supervisor Document

You create a new AppleLine Supervisor document as follows:

1. Open a new MacTerminal document.
2. Leave the Terminal settings as they are, and change Compatibility as shown below.
3. Use the Save As command from the File menu to name the document and save the settings.

Compatibility Settings



Baud Rate 50 75 110 134.5
 150 200 300 600
 1200 1800 2000 2400
 3600 4800 9600 19200

Bits per Character 7 Bits 8 Bits

Parity Even Odd None

Handshake HDn/HOff None

Connection Modem Another Computer

Connection Port  

Using Your Macintosh as an IBM 3278

When the AppleLine is operating, you can use your Macintosh with MacTerminal to work with an IBM mainframe, just as if you were seated at an IBM Model 3278 terminal. A typical session consists of three parts:

- Setting up communication between your Macintosh and the IBM system by a series of log-on procedures.
- Working with the IBM system by typing messages on your Macintosh keyboard and reading replies on your Macintosh screen.
- Terminating communication between your Macintosh and the IBM system by a series of log-off procedures.

The first and third parts, logging on and logging off, are described in Chapter 5, Part I, of the *AppleLine User's Manual*. The second part, using your Macintosh controls and keyboard to work with the IBM system, is covered in this section.

Terminal Controls

The IBM Model 3278 terminal has the following controls for which the Macintosh has equivalents:

- Knobs vary the brightness and contrast of the screen image and change the volume of the audible alarm.

On the Macintosh, you adjust brightness with the control below the screen; you adjust the volume with the Control Panel in the Apple menu.

(See Chapter 4, “Macintosh Reference,” in *Macintosh*, your owner’s guide.)

If you set the volume to zero, MacTerminal flashes the menu bar to signal that the host computer has sent a bell (beep).

- A Dual Case/Mono Case switch determines whether your typing appears as uppercase and lowercase letters or uppercase (capitals) only. On the Macintosh keyboard, the Caps Lock key provides this function.

The Macintosh Keyboard

When you type ordinary letters, numbers, and punctuation marks on your Macintosh keyboard, most IBM programs understand them in the normal way. They are exactly equivalent to the letters, numbers, and punctuation marks on the IBM 3278 keyboard. However, there are other keys on the 3278 keyboard that have special markings (such as SYS REQ and ATTN) that identify the special functions they perform.

For the meaning and use of these special IBM function keys, consult the appropriate IBM manuals, particularly the *IBM 3278 Display Station Operator’s Guide*.

The Macintosh provides the equivalent of these function keys on a keypad in the Keypad menu. You can use these special functions by positioning the pointer on the Keypad menu title, pressing down the mouse button, dragging to the function key you want, and releasing the mouse button.

Keypad

PF1	PF2	PF3	PF4	PF5	PF6	PF7	PF8	PF9	PF10	PF11	PF12
PF13	PF14	PF15	PF16	PF17	PF18	PF19	PF20	PF21	PF22	PF23	PF24
PA1	PA2	Attn	Print	Home	Erase EOF	Delete	Erase Input	Insert	Reset	Sys Req	Clear

If you have a numeric keypad, you can use it to imitate the function keys on the IBM 3278. You get one set of PF equivalents simply by pressing the key, another by pressing the Command key at the same time that you press the key, and a third by pressing the Option key at the same time that you press the key.

Attn <i>Sys Rec</i> Clear	Not Used <i>PF22</i> PF10	Not Used <i>PF23</i> PF11	Not Used <i>PF24</i> PF12
Ident <i>PF19</i> PF7	↑ <i>PF20</i> PF8	Not Used <i>PF21</i> PF9	Dup <i>PA1</i> Insert
← <i>PF16</i> PF4	Home <i>PF17</i> PF5	→ <i>PF18</i> PF6	Field Mark <i>PA2</i> Delete
Print <i>PF13</i> PF1	↓ <i>PF14</i> PF2	Not Used <i>PF15</i> PF3	Back Tab <i>Enter</i> Enter
Not Used <i>Dev Cancel</i> Reset	Not Used <i>Erase Input</i> EraseEOF		

With the Option Key

With the Command Key

Regular Use

Or you can activate these functions by pressing certain combinations of standard keys on your Macintosh or Macintosh Plus keyboard. The IBM 3278 Keyboard Equivalents Table lists these combinations, arranged in the order in which their functions are described in the *IBM 3278 Display Station Operator's Guide*.

IBM Keys	Apple Keystrokes	IBM Keys	Apple Keystrokes
DUP	CONTROL-U	PF22	ESCAPE J
FIELD MARK	CONTROL-Y	PF23	ESCAPE _
PA 1	ESCAPE I	PF24	ESCAPE +
PA 2	ESCAPE J	NEW LINE	RETURN
PF 1	ESCAPE 1	TAB	TAB
PF 2	ESCAPE 2	BACK TAB	CONTROL-K
PF 3	ESCAPE 3	HOME	CONTROL-\
PF 4	ESCAPE 4	ATTN	CONTROL-A
PF 5	ESCAPE 5	SYS REQ	CONTROL-B
PF 6	ESCAPE 6	CURSR SEL	CONTROL-D
PF 7	ESCAPE 7	CLEAR	CONTROL-E
PF 8	ESCAPE 8	ERASE INPUT	CONTROL-L
PF 9	ESCAPE 9	ERASE EOF	CONTROL-F
PF 10	ESCAPE 0	PRINT	CONTROL-P
PF 11	ESCAPE -	IDENT	CONTROL-V
PF 12	ESCAPE =	TEST	CONTROL-T
PF 13	ESCAPE !	RESET	CONTROL-R
PF 14	ESCAPE @	DEV CNCL	CONTROL-X
PF 15	ESCAPE #	INSERT	CONTROL-I
PF 16	ESCAPE \$	DELETE	CONTROL-BS
PF 17	ESCAPE %	ENTER	ENTER
PF 18	ESCAPE ^	LEFT CURSOR	←
PF 19	ESCAPE &	RIGHT CURSOR	→
PF 20	ESCAPE *	UP CURSOR	↑
PF 21	ESCAPE (DOWN CURSOR	↓

MacTerminal redefines two keys on the Macintosh keyboard to act as the Control and Escape keys.

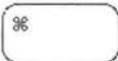

The Command key, located to the left of the space bar, is the Control key.



The key located in the upper-left corner of the keyboard is the Escape key. Note also that the Enter key on the Macintosh keyboard is the Enter key for a 3278 terminal. Press the Shift key and Enter for a long “break.” (When MacTerminal is set to VT100 terminal type, the Enter key is the Break key.)

The Macintosh Screen Display

You use the Control key by holding down the key while pressing some other key. For instance, Control-U means to hold down the Control key while pressing U once.

You use the Escape key by pressing the key and then pressing some other key. For instance, Escape-1 means to press Escape once and then press 1 once.

For your convenience, a copy of the table is printed on a tear-out card in the back of the *AppleLine User's Manual*. You can remove the card and post it near your Macintosh for ready reference.

When you're using your Macintosh to communicate with an IBM or IBM-compatible mainframe, the screen display looks very much like the screen on an IBM 3278 terminal and differs slightly from the usual MacTerminal display:

- The main area of the screen presents data from the mainframe in the usual 80-column format; however, the main area is 24 lines long, and IBM's Status Information Area appears as the bottom line (line 25) of the MacTerminal display.
- The appearance of the IBM status symbols on the status line will be different on MacTerminal.
- The appearance of the IBM cursor may be different on MacTerminal.

These differences may or may not be apparent, depending on how the IBM program you're using is constructed.

To use the support available through the Status Information Area, open your AppleLine Supervisor document. Start up AppleLine and wait for the message to "Enter Password." Enter the current Supervisor password. Choose B on the menu; you are going to modify the terminal type. On the set of options that appears, change the terminal settings to the ones shown in the illustration:

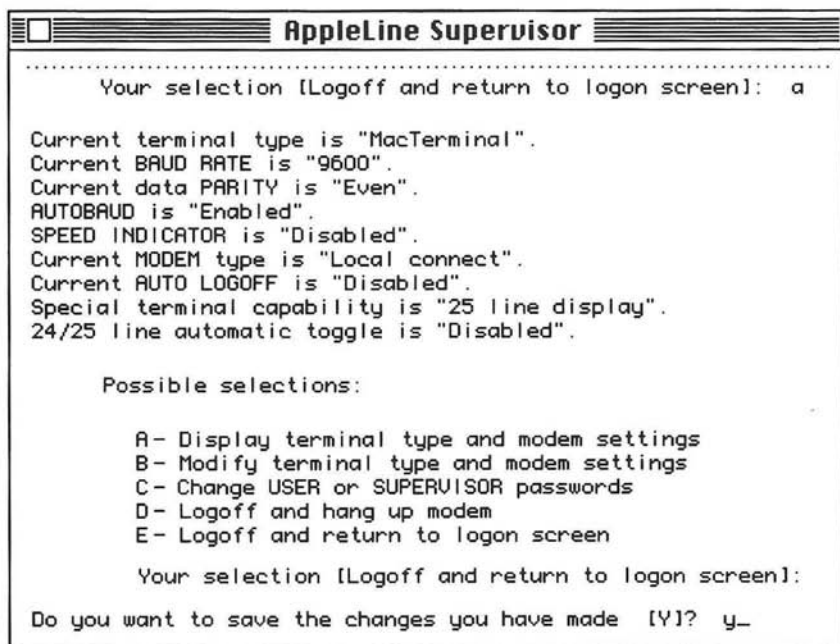

Once you've made and saved these changes, close the AppleLine Supervisor document. You only need to change these settings once; from now on, you'll be able to use the support available through the 25th (or status) line.

Appendix D: Installing the Apple Cluster Controller

Direct Connection

You'll need the *Apple Cluster Controller User's Manual: Part I—Reference* to complete the hookup of the Macintosh. You can connect your Macintosh to the Apple Cluster Controller (ACC) directly or through a modem.

To connect your Macintosh directly to the Apple Cluster Controller, you need a data cable with a pin-plug connector on either end—one to connect to a 9-pin socket and a larger one to connect to a 25-pin socket.

1. Turn off the Macintosh and the Apple Cluster Controller.
2. Attach the small connector on the data cable to the Modem port, marked with a symbol of a telephone, on the back of the Macintosh.

The Modem port is usually recommended for data communications. However, if you have a hard disk connected to the Modem port, connect your cable to the Printer port.

3. Attach the large connector on the cable to one of the seven ports on the back of the Apple Cluster Controller.

You can usually attach the cable from the Macintosh to any of these ports, but consult someone familiar with your Apple Cluster Controller configuration to determine the correct port. Some models reserve a port for other uses.

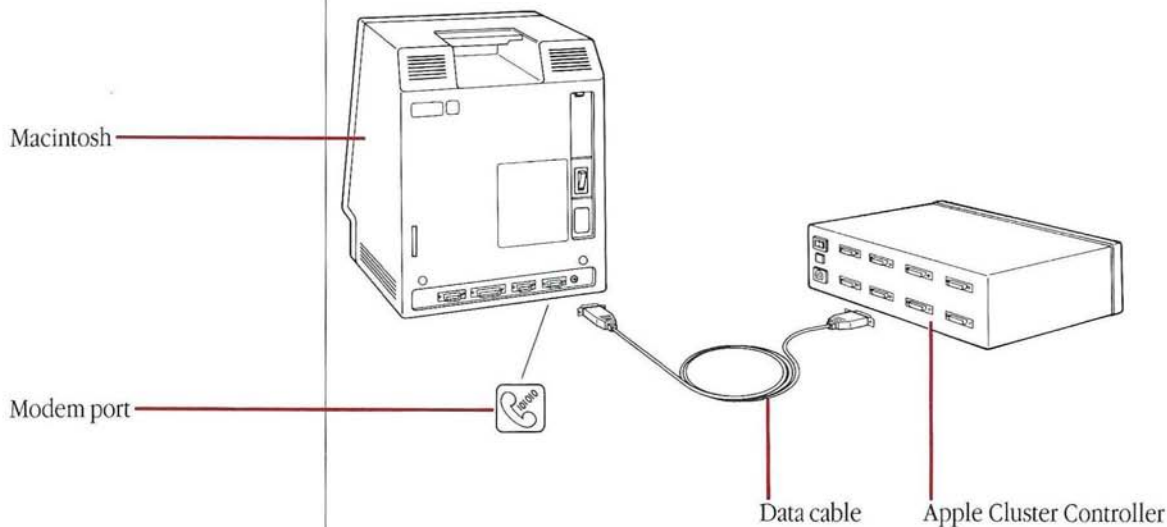

Modem Connection

To communicate with an IBM or IBM-compatible mainframe by a modem, you need a modem attached to your Macintosh and one attached to the Apple Cluster Controller.

Refer to the *Apple Cluster Controller User's Manual: Part I—Reference* for instructions on installing a modem to the Apple Cluster Controller.

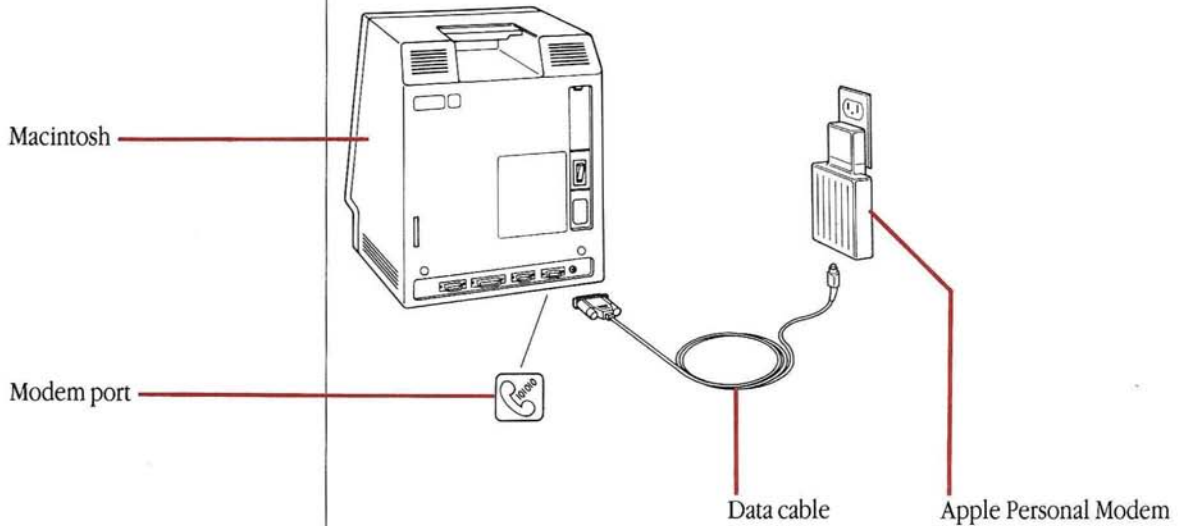

Setting Up MacTerminal

The MacTerminal disk provides a document named Apple Cluster Controller that's preset to communicate between your Macintosh and the Apple Cluster Controller. If you use it and are directly connected to the Controller, you only need to make sure the baud rate matches the speed of the Apple Cluster Controller. If you're using a new MacTerminal document, be sure to set it up as described here.

1. Choose Terminal from the Settings menu and set the Terminal options as follows.

- Terminal Type—IBM 3278
- Protocol Conv (Converter)—Cluster Controller
- On Line—On
- Auto Repeat—On
- Repeat Ctrl's (Controls)—Off

The following figure illustrates the preset options of the Terminal command.

Terminal Settings			
Terminal	<input type="radio"/> UT100	<input type="radio"/> TTY	<input checked="" type="radio"/> IBM 3278
Mode	<input checked="" type="radio"/> ANSI	<input type="radio"/> VT52	
Cursor Shape	<input checked="" type="radio"/> Underline	<input type="radio"/> Block	
Line Width	<input checked="" type="radio"/> 80 Columns	<input type="radio"/> 132 Columns	
Protocol Conv	<input type="radio"/> AppleLine	<input checked="" type="radio"/> Cluster Ctrl	
<input checked="" type="checkbox"/> On Line	<input type="checkbox"/> Local Echo	<input type="checkbox"/> Status Lights	
<input checked="" type="checkbox"/> Auto Repeat	<input type="checkbox"/> Auto Wraparound	<input type="checkbox"/> New Line	
<input type="checkbox"/> Repeat Ctrl's	<input type="checkbox"/> Transparent	<input type="button" value="OK"/>	<input type="button" value="Cancel"/>

2. Choose Compatibility from the Settings menu and set the Compatibility options as follows:
- Choose the baud rate that matches the baud rate of the Cluster Controller.
 - Bits per Character—7 Bits
 - Parity—Even
 - Handshake—XOn/XOff
 - Connection—Modem or Another Computer, depending on how your Macintosh is connected to the Apple Cluster Controller
 - Connection Port—Modem port (or Printer port, although it's not recommended)

The preset options of the Compatibility command are shown in the following figure.

Compatibility Settings



Baud Rate 50 75 110 134.5
 150 200 300 600
 1200 1800 2000 2400
 3600 4800 9600 19200

Bits per Character 7 Bits 8 Bits

Parity Even Odd None

Handshake XOn/XOff None

Connection Modem Another Computer

Connection Port  

**Appendix E:
MacTerminal as a
DEC VT100**

MacTerminal implements all of the features of the DEC VT100 terminal with AVO (Advanced Video Options, such as boldfacing and inverse characters) except the following:

- margin bell
- key click
- smooth scroll
- blinking character attribute
- remote diagnostic (loopback) text mode
- dark screen background as the normal text display mode

Appendix F: ASCII Control Characters

Key	Code (Dec)	Code (Hex)	Abbrev.	Name
CONTROL-SPACE	00	\$00	NUL	Null
CONTROL-A	01	\$01	SOH	Start of Header
CONTROL-B	02	\$02	STX	Start of Text
CONTROL-C	03	\$03	ETX	End of Text
CONTROL-D	04	\$04	EOT	End of Transmission
CONTROL-E	05	\$05	ENQ	Enquiry
CONTROL-F	06	\$06	ACK	Acknowledgment
CONTROL-G	07	\$07	BEL	Bell
CONTROL-H	08	\$08	BS	Backspace
CONTROL-I	09	\$09	HT	Horizontal Tab
CONTROL-J	10	\$0A	LF	Line Feed
CONTROL-K	11	\$0B	VT	Vertical Tab
CONTROL-L	12	\$0C	FF	Form Feed
CONTROL-M	13	\$0D	CR	Carriage Return
CONTROL-N	14	\$0E	SO	Shift Out
CONTROL-O	15	\$0F	SI	Shift In
CONTROL-P	16	\$10	DLE	Data Link Escape
CONTROL-Q	17	\$11	DC1 (XOn)	Device Control 1
CONTROL-R	18	\$12	DC2	Device Control 2
CONTROL-S	19	\$13	DC3 (XOff)	Device Control 3
CONTROL-T	20	\$14	DC4	Device Control 4
CONTROL-U	21	\$15	NAK	Negative Acknowledgment
CONTROL-V	22	\$16	SYN	Synchronization Character
CONTROL-W	23	\$17	ETB	End-of-Transmission Block
CONTROL-X	24	\$18	CAN	Cancel
CONTROL-Y	25	\$19	EM	End of Message
CONTROL-Z	26	\$1A	SUB	Substitute
CONTROL-[27	\$1B	ESC	Escape
CONTROL-\	28	\$1C	FS	Forms Separator
CONTROL-]	29	\$1D	GS	Group Separator
CONTROL-^	30	\$1E	RS	Record Separator
CONTROL-_/	31	\$1F	US	Unit Separator
CONTROL-BS	127	\$7F	DEL	Delete

Appendix G: Pin Assignments for the Apple Modem Data Cable

Pin	Meaning
1	Cold (Chassis) Ground.
2	+5 Volts Filtered. (Do not draw current from this pin.)
3	Cold (Chassis) Ground. Can be used for signal ground.
4	Transmit Data Plus.
5	Transmit Data Minus.
6	+12 Volts Filtered. (Do not draw current from this pin.)
7	Handshake Input. (Goes to Plus side of a receiver whose Minus side is grounded for reference.)
8	Receive Data Plus.
9	Receive Data Minus.

Glossary

access telephone number

The telephone number of the other computer. You enter this number in the Phone Settings dialog box from the Phone menu and you have MacTerminal dial it with the Dial command.

ANSI

Acronym for *American National Standards Institute*, which sets standards for many technical fields, including computer terminals. Normally, the VT100 follows these standards—unless it has to imitate the older VT52 terminal. When you select VT100 in the Terminal Settings dialog box, you get to choose which mode you want—ANSI or VT52. The IBM 3278 follows ANSI standards, but does not offer you the ability to imitate the VT52.

Answerback

A Setting that allows you to set up a message identifying MacTerminal to another computer. The message depends on what the other computer requires. The message lets the other computer know that contact has been established.

Apple menu

The menu on the far left in the menu bar, from which you choose desk accessories. Its title is an apple symbol.

application

A computer program that puts the resources of the computer to use for some specific purpose, such as word processing or telecommunications.

ASCII

Acronym for *American Standard Code for Information Interchange*, pronounced *ASK ee*. A code in which the numbers from 0 to 127 stand for text characters—including the letters of the alphabet, the digits 0 through 9, punctuation marks, special characters, and control characters. Used for representing text inside the computer and for transmitting text between computers. The Text and XModem Text protocols transfer files consisting only of ASCII characters; such files are also known as *text files*.

Auto Repeat

An option that automatically repeats a character for as long as you hold down the key. You can make this possible, or stop it, by using the Terminal command on the Settings menu.

Auto Wraparound

An option on Terminal Settings, telling MacTerminal that when text reaches the last column, it should spill over into the next line. Otherwise, the cursor stops at the last column, and every new character overwrites the last. You can also have MacTerminal break lines after a word—rather than within a word—when you send out text; on File Transfer Settings, check Word Wrap Outgoing Text.

Backspace

Backspace key

A key that moves the cursor back one space. Using the Keyboard command on the Settings menu, you can decide whether pressing the Backspace key will move you back one character, or delete that character.

baud rate

The speed at which your data is being transmitted. The baud rate is equal to the number of discrete signals per second. Rough rule of thumb: divide the baud rate by ten to find out the characters-per-second.

Break key

In MacTerminal, the Enter key functions as the Break key when pressed at the same time as the Option key. Press Option-Enter to send a break. Press Shift-Enter to send a long break.

Calculator

A desk accessory that works like a four-function pocket calculator. Calculation results can be cut and pasted into the terminal display.

Cancel button

A button that appears in dialog boxes. Clicking this button cancels the command.

carrier

The signal on a communication channel. It is modified to *carry* the information. If you get the message “No carrier,” it means that you are not connected with the other computer.

character set

The entire collection of characters that can be shown on the screen or used to code computer instructions. MacTerminal has 14 character sets from which to choose a primary character set—the one that is usually displayed—and an alternative set. On the Settings menu, choose Character Sets to specify which one you want to be currently active.

Christensen protocol

Ward Christensen developed the XModem protocol, an agreement between two computers about how they'll exchange data. This method sends data and keeps on sending it until it gets there. It does not give up when it discovers an error; it resends the correct version.

Clear Lines Off Top

Tells MacTerminal to erase everything it has recorded above the dotted line, when MacTerminal is recording information as the lines roll off the top of your screen. Commands menu.

click

To position the pointer on something, and then press and quickly release the mouse button.

Clipboard

The holding place for what you last cut or copied. Maximum size: 32,000 characters, or approximately 16 pages of single-spaced text.

close box

The small white box on the left side in the title bar of an active window. Clicking a close box closes the window and removes the window from the desktop.

command

A word or phrase, usually in a menu, describing an action for the Macintosh to perform. Choosing a command causes the action to take place. Some commands have an equivalent keyboard combination of the Command key and a character key that accomplishes the same thing.

Command key

See **Control key**. The Command key does not have its normal function while using MacTerminal.

communications session

The activity during the time you are connected to the other computer and accessible by the other computer. You make a connection to the other computer by a direct cable or by a modem and telephone lines.

compatibility

The ability of one computer to get along with another. On the Settings menu, the Compatibility command allows you to control the speed, format, error-checking, and physical connections used in sending or receiving data between computers.

connection

The physical link between your Macintosh and the other computer. You can link them directly or through modems. If you connect to the other computer by telephone, you attach your Macintosh to a device called a modem, which sends data from MacTerminal over the telephone lines to another modem at the other end, which in turn sends the data on to the other computer. When you use a special cable to attach your Macintosh directly to an IBM mainframe and you want your Macintosh to emulate an IBM 3278 terminal, the Apple Cluster Controller or the AppleLine acts as an intermediary.

connect time

The elapsed time between the moment MacTerminal makes contact with another computer, starting a communications session, and the moment when you terminate the connection.

control character

An ASCII character used as a command to a computer, terminal, or printer. See **Control key**.

Control key

In MacTerminal, the Command key functions as the Control key—a key that when pressed with another key issues a command. When you type *H*, the computer considers it just another letter in the alphabet, but when you press CONTROL-H the computer considers it a command.

Control Panel

A desk accessory that lets you change the speaker volume, the keyboard repeat speed, and other preferences.

cursor

A blinking underline (or solid rectangle) that marks the position of the next incoming or outgoing character shown in the terminal display area.

cursor key

A key on the numeric keypad that can function as a cursor key when you've chosen a VT100 terminal type. Cursor keys move the cursor vertically or horizontally in the terminal display area and may be needed to use the application on the host computer.

cut

To remove something from a desk accessory by selecting it and choosing Cut from the Edit menu, which places the selection on the Clipboard. Data in a MacTerminal document can be copied but not cut.

data

Information, especially information used or operated on by a program. Characters that convey meaningful text or graphics. Distinguished from arrangement (for instance, characters that announce that the information is about to start, or has just stopped) or error-checking (for instance, characters that are put in to help make sure that there have been no mistakes in transmission).

delay

A deliberate slowing down, as when you add a time interval between characters or between lines while you send them. Sometimes the other computer cannot receive information as fast as MacTerminal sends it, and no adjustment of the baud rate helps. In this case, you can go to the Settings menu and choose File Transfer to tell MacTerminal to insert a one-second delay between lines or characters, increasing the delay gradually until the other computer can read you.

desk accessories

“Mini-applications” that are available from the Apple menu regardless of which application you’re using. Examples are the Calculator, Note Pad, Alarm Clock, and Puzzle.

desktop

Macintosh’s working environment—the menu bar and the gray area on the screen.

Dial

A command on the Phone menu telling MacTerminal to dial the phone number you entered into Phone Settings.

dialog box

A box that contains a message requesting more information from you. A dialog box has places to enter information and choose options.

dimmed command

A command that appears lighter and grayer than other commands in the menu. When a command is dimmed, it cannot be chosen.

dimmed icon

An icon that represents a disk—or a document, folder, or application on a disk—that has been ejected. Any dimmed icon can be selected. Dimmed disks and folders can be opened; dimmed documents and applications can't be.

DIP switch

A bank of tiny switches, each of which can be moved manually one way or the other to represent one of two values (usually on and off). *DIP* stands for *dual in-line package*.

disk

The magnetic medium on which the Macintosh stores information.

disk drive

The mechanism that holds the disk, retrieves information from it, and saves information on it. Macintosh has an internal disk drive, and you can add an external one, or a hard disk.

document

Whatever you create with Macintosh applications—information you enter, modify, view, or save. In MacTerminal, a document provides the options for setting up a communications session and the display area to view incoming and outgoing data. A document can also contain data that you've instructed MacTerminal to record and save.

double-click

To position the pointer where you want an action to take place, and then press and release the mouse button twice in quick succession without moving the mouse.

drag

To position the pointer on something, press and hold the mouse button, move the mouse, and release the mouse button. When you release the mouse button, you either confirm a selection or move an object to a new location.

EBCDIC

Acronym for *Extended Binary Coded Decimal Information Code*.

(Pronounced *EB-si-dik*.) An IBM code that represents each letter, number, special character, and control character as an 8-bit binary number. EBCDIC has a character set of 256 8-bit characters.

echo

For a host computer to retransmit every character it receives back to the terminal that sent it. Most computers use echo to confirm the connection continually.

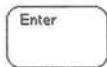
**emulator**

Imitator. MacTerminal is an application that can *emulate* several different terminals; it is a terminal emulator.

Enter key

A key that confirms or terminates an entry or sometimes a command. In VT100 emulation, the Macintosh Enter key is equivalent to the Break key. In IBM 3278 emulation, the Macintosh Enter key is equivalent to IBM's Enter key.

error message

A message from the computer indicating that a function, command, or entry cannot be performed or accepted. Error messages are often accompanied by a beep.

Escape key

In MacTerminal, the Escape key is the accent/tilde key at the upper-left corner of the keyboard.

escape sequence

A sequence of keystrokes beginning with the Escape key, often used for positioning the cursor and controlling the display of text on the screen.

file

A collection of information stored on a disk; usually a document. Macintosh files include documents, system files, and text files.

File Transfer

A command on the Settings menu that allows you to specify what file transfer protocol you want to use, how you want to save information that comes across your screen, and how you want to send out information. Transferring a file involves sending it from one computer to another. A File Transfer protocol establishes the way each computer will send and receive that file. MacTerminal offers several File Transfer protocols. Between Macintoshes, use MacTerminal 1.1. Between your Macintosh and most information services, use MacBinary. When communicating with an IBM mainframe, or a computer that can handle only sequences of ASCII characters (text files), use Text.

Finder

An application that's always available on the desktop. You use it to manage documents and applications and to gain access to the contents of disks.

font

A collection of letters, numbers, punctuation marks, and other typographical symbols with a consistent appearance. The font used by MacTerminal is Monaco.

font size

The size of characters in text. The Monaco font in MacTerminal is 9 point. There are 72 points to an inch, so the font is an eighth of an inch high, from the top of a capital *T* to the bottom loop of a lowercase *g*.

format

The arrangement of text as determined by the margins, tabs, line spacing, and text alignment.

full duplex

A communications link capable of simultaneous two-way transmission; allows the other computer to echo received characters back to MacTerminal's display.

function key

A key that performs special functions usually determined by the application of the other computer. Function keys for the VT100 and the IBM 3278 appear on MacTerminal's Keypad menu.

half-duplex

A communications link between the host computer and MacTerminal in which only one device can transmit at a time, as with walkie-talkies. The host computer cannot echo what you send, so your screen appears blank until you choose Terminal on the Settings menu, and check Local Echo.

handshake

A protocol for devices to exchange information about the communications connection itself, such as when to start and stop transmitting. MacTerminal uses the XOn/XOff handshake method.

hard disk drive

A device that holds a hard disk, retrieves information from it, and saves information to it. A hard disk can store much more information than a 3.5 inch single- or double-sided disk.

hide

To remove from the display. On the Edit menu, you can choose Show Clipboard, then Hide Clipboard; similarly, on the Settings menu, you can choose Show Tab Ruler, then Hide Tab Ruler.

highlight

To make something visually distinct from its background. An item is usually highlighted to show that it has been selected or chosen.

host computer

A computer that manages information for many terminals. A host computer may be a mainframe, minicomputer, or another microcomputer. (The microcomputer might be running an electronic bulletin board, for example.)

icon

A graphic representation of an object, a concept, or a message.

initialize

To prepare a disk to receive information.

insertion point

The spot where something will be added. An insertion point is selected by clicking and is represented by a blinking vertical bar. In MacTerminal, insertion points appear only in dialog boxes where you're asked to type information.

Key Caps

A desk accessory that shows you foreign characters and special symbols.

Keypad menu

Provides you with the on-screen equivalent of the Macintosh numeric keypad, imitating the function and cursor keys of the VT100, or the function keys of the IBM 3278, depending on which terminal you checked (Settings menu: Terminal). You can "press" a key by choosing it from the open menu.

line feed

An ASCII character (decimal 10) that ordinarily causes the cursor to drop down to the next line—in the same column it was in before. MacWrite does not normally put a line feed at the end of each line, but the other computer may need line feeds. If it does, you can set MacTerminal to insert a line feed at the end of each line, to break the lines at the right spot. When New Line is checked on the Terminal settings, and you are sending text, MacTerminal adds a line feed after every Return. The cursor drops to the next line and then zips back to the beginning of that line. If you are receiving data and it all ends up on one line, check New Line on the Terminal settings; MacTerminal will then act on any line feed it receives.

local echo

A method of communication in which MacTerminal displays data "locally" in the terminal display area as you send it, without relying on the host computer to echo the characters back.

log off

To type a command to the host computer that terminates the communications session.

log on

To enter a series of responses to prompts by the host computer, at the beginning of a communications session, to identify yourself, your account number, sometimes your terminal, and so forth.

mainframe computer

A large computer whose speed and storage capacity allow it to handle huge amounts of data and work with many terminals.

menu

A list of commands that appears when you point to and press the menu title in the menu bar. Dragging through the menu and releasing the mouse button while a menu item is highlighted chooses that item.

menu bar

The horizontal strip at the top of the screen that contains menu titles.

mode

In MacTerminal, one of two ways a VT100 terminal behaves: it can be in its standard mode, as defined by the American National Standards Institute (ANSI mode), or it can imitate an earlier terminal, the VT52 (VT52 mode). You set the mode in the Terminal Settings dialog box.

modem

Short for *MOdulator/DEModulator*. A peripheral device that links your Macintosh with other computers and information services via telephone lines.

Note Pad

A desk accessory that allows you to enter and edit small amounts of text while working in a MacTerminal document.

numeric keypad

A set of keys arranged as on a calculator, for rapid entry of numbers. There is a physical keypad—it may be part of your regular keyboard, or an accessory unit—and an on-screen equivalent. If you do not have the physical keypad, you can pull down the Keypad menu and choose keys the way you would menu items. With the VT100 or IBM 3278 terminal types, the keys on the numeric keypad take on special functions defined by the applications running on the other computer.

off-line

Describes equipment and activities connected to but not accessible by the other computer because you've temporarily interrupted (without terminating) your session to do something else.

on-line

Currently connected to and under the control of the host computer. When MacTerminal is on-line to the host computer, the host computer defines much of what you can do.

open

To create a window so you can view the contents of a disk, document, or text file.

Option key

A key used like the Shift key to give an alternate interpretation to another key you type.

parallel transmission

A way of transmitting data, in which several bits of information (typically eight bits or one byte) are transmitted simultaneously over several different wires or channels.

parameter

A variable that determines the outcome of a command by setting limits, rates, or levels. You set many communications parameters by choosing commands on the Settings menu. For instance, in establishing the speed of transmission, or baud rate, 1200 is a common parameter.

parity

A method of detecting errors in data transmission. The computer that sends a piece of data adds a bit, and the receiving computer looks at that bit to make sure that it maintains a sameness (or parity) of level or count. If not, the assumption is that an error has been made somewhere along the line. There are several kinds of parity, and when you find out what the other computer expects, you can set MacTerminal to perform the same operation; on the Settings menu, choose Compatibility. Because they have better quality telephone lines, some host computers do not need to set up any form of parity.

paste

To place the contents of the Clipboard—whatever was last cut or copied—into a document, text file, or desk accessory. Pasting into a MacTerminal document during a communications session sends the data to the remote computer.

port

The connection sockets on many peripheral devices through which data is transmitted. The Macintosh Modem port is the only one recommended for both sending and receiving data. The Printer port may not receive data accurately if you send it at speeds over 1200 baud.

Print Selection

A File command, telling MacTerminal to print what you have selected in the document. A dialog box appears, allowing you to adjust quality, page range, number of copies, and type of paper.

prompt

A query or advisory message from a host computer to the terminal user, such as a request to type a password or choose a command.

protocol

A set of rules for sending and receiving data on a communications line. Devices such as the Apple Cluster Controller and AppleLine convert data from one protocol to another; they are known as *protocol converters*.

Receive File

A command that prepares MacTerminal to receive a file. If you have chosen MacBinary, XModem Text, or Straight XModem as the protocol (Settings menu: File Transfer), and are about to receive a file, choose this command on the File menu.

Record Lines Off Top

To save lines as they scroll off the top of your screen, and put them in your document on disk. Choose this on the Commands menu; when you choose it, the command changes to "Don't Record Lines Off Top," so you can stop the process. Must be on to use Save Screens Off Top (Settings menu: File Transfer).

Save

To transfer information from your Macintosh to a disk, for storage.

Scrapbook

A desk accessory in which you can save frequently used pictures or passages of text.

scroll

To move information in a window so that a different part of it is visible.

scroll area

The region, defined by a host computer, above which lines of data move out of your view. The scroll area is usually the entire terminal display area but may be a smaller region within it.

scroll arrow

An arrow on either end of a scroll bar. Clicking a scroll arrow moves the document or directory one line. Pressing a scroll arrow scrolls the document continuously.

scroll bar

A rectangular bar that may be along the right or bottom of a window. Clicking or dragging in the scroll bar causes the view of the document to change.

scroll box

The white box in a scroll bar. The position of the scroll box in the scroll bar indicates the position of what's in the window relative to the entire document.

select

To designate where the next action will take place. To select, you click, double-click, or drag across information. In MacTerminal, you can select data to copy it to another application. The selection is usually highlighted.

send

To transfer information. Once you have started a communication session, you can Paste information into your document; that information will be sent automatically to the other computer. To send a whole file, choose Send File on the File menu.

serial port

A socket on the back of the Macintosh that allows you to connect it to serial communications devices—modems, printers, other computers, and so forth.

serial transmission

A way of transmitting data, in which one bit is sent at a time, sequentially, over a single wire or channel. Serial cables plug into serial ports. On the Macintosh, the serial ports are the Modem port and the Printer port.

Shift-click

A technique that allows you to extend or shrink a selection by holding down the Shift key while you revise your selection.

Shift key

A key that, when you hold it down, causes subsequently typed letters to appear in uppercase and causes the upper symbol to appear when you press number or symbol keys.

size box

A box on the bottom right of some active windows that lets you control the size of the window.

software

Programs, or instructions for the Macintosh to carry out. The Macintosh reads these instructions from disks inserted into the disk drive.

startup disk

A disk with all the files you need to use the Finder and possibly one or more applications.

status lights

Some terminals, such as the VT100, have a series of lights that report on the condition of the terminal and the program running on the host computer. One shows whether you are on-line or not, another whether the keyboard is locked. The meaning of others depends on the program you are using on the host computer. You can have MacTerminal simulate these status lights by going to the Settings menu, choosing Terminal, picking VT100, and then checking Status Lights.

status line

The IBM Status Information Area that appears on the 25th line of a MacTerminal display when you are emulating an IBM 3278 terminal through the AppleLine. Gives you information about your 3278 session.

system file

Any of the files normally found in the System Folder.

tab marker

A filled diamond on the tab ruler, indicating the position to which pressing the Tab key will move the insertion point.

tab ruler

A ruler in MacTerminal that lets you change tabs for incoming tables that contain tab stops.

terminal

A device that lets you communicate with a host computer through a keypad and display or printer.

terminal emulator

An application used to make a personal computer act like a terminal to a host computer. The application usually emulates (mimics) a certain popular brand of terminal; MacTerminal emulates the DEC VT100 and the IBM 3278, as well as a TTY, the standard teletype-like terminal.

text

Information in the form of characters readable by human beings. A text file is encoded using the ASCII format. You can create text files in most applications; for instance, from MacWrite, choose Save As, and check Text Only, then save. You can transfer a text file by the Text or XModem Text protocols.

title bar

The horizontal bar at the top of a window that shows the name of the window's contents and lets you move the window.

transfer

To send or receive information between computers.

transmit

To send information to the other computer.

TTY

Stands for *Teletypewriter*, a Teletype terminal that ignores many of the commands from the remote computer that the VT100 or IBM 3278 can respond to. The TTY responds to Return, Tab, Backspace, and Line Feed characters, ignoring other control characters and all escape sequences.

window

The area that displays information on a desktop. You view documents through windows. You can open or close windows, change their size, edit their contents, scroll through them, and move them around on the desktop.

XModem Text

The File Transfer protocol to use for sending plain text (ASCII characters without font or format information) from your Macintosh to another type of computer—if that computer supports the XModem protocols. More reliable than the Text protocol.

XOn/XOff

A handshake protocol (transmit-On/transmit-Off) used by computers and intelligent terminals to control the flow of data between the systems so that one system isn't overloaded.

Index

A

About MacTerminal command 53
access number 9, 17, 31, 32, 82, 122
 format 31, 82
 entering 16, 82, 106
account number, logging on 18
Advanced Video Options, VT100 terminal 119
alternate character set 78
alternate keys, use of 20
Alternate ROM Graphics character set 79
ANSI mode setting 66, 122
Answerback message 18, 77, 122
answering incoming calls 18
Apple Cluster Controller 5, 30, 67, 104
 document 117
 installing 115-18
Apple Hard Disk 20 30, 35, 73, 88
AppleLine 103
 Controller device 5
 document 30, 104
 installing 101-14
 protocol converter setting 67
 Supervisor document 30, 106-09
 supervisor program 106-09
Apple menu commands 52-53
Apple Modem 5, 16, 31, 81, 83, 86, 103, 116 *See also* modem
 during transmission 18
 ending transmission 25
 originating calls through 32
 receiving calls through 32, 87
Apple Personal Modem 5, 87, 103, 116
AppleTalk modem connections 100
Apple II 34
applications 122
 opening MacTerminal document with 42
 sending applications file 38
 using on host 21, 24
arrow keys 84, 96-99
ASCII 122
 characters, in transfer 15, 76
 control characters, list of 120
 files 13, 76
audible signals 18
autobaud message 106
Auto Link 212A 5

Auto Repeat setting 11, 69, 122 *See also* Repeat Ctrl's setting
Auto Wraparound setting 11, 12, 30, 36, 37, 69, 123

B

Backspace key 123
 setting 20, 70, 79
baud rate 9, 10, 11, 14, 30, 32, 71, 73, 106, 117, 123
 setting for modem 16, 38, 71
Baud Rate setting 30, 70, 72, 104
bits per character 10, 71
Bits per Character setting 30, 70
bits per second 10, 71
blank page icon 23
blinking character VT100 attribute 119
Block cursor shape setting 66-67
Boich, Mike 53
bps *See* bits per second
Break key 123
 in log-on sequence 20, 95, 98
bytes, in relation to file size 47

C

cable assembly, for AppleLine 102
Calculator 123
Cancel button 30, 123
Caps Lock key 110
capturing screen information 22
carrier 123
changing disks *See* disk
characters
 free on disk 53
 stored off top 53
character set 78-79, 123
Character Sets command 78-79
Christensen, Ward 15, 76
Clear command 63
Clear Lines Off Top command 21, 64, 124
Clipboard 22, 24, 36, 37, 43, 63, 124
Close file command 45, 55
Cluster Ctrl protocol converter setting 67
columns
 in tables, and copying 43, 62, 80
 of characters 66, 67 *See also* Line Width setting
Command key 20, 33, 35, 70, 79, 85, 86, 95-99, 111, 112-13,
 124 *See also* Control key
Commands menu 21, 63
Commercial Services document 9, 30, 88
communicating
 by cable *See* connection

- with host computer *See* host computer
- with personal computer 21, 40, 63, 74
 - common settings 40
 - connecting to 18
 - settings for 30, 40, 65-80
 - with another Macintosh 34, 38, 76
 - with Apple II 34
- communication networks 40
- communications parameters 3, 8, 10, 11, 70, 106
- communications problems *See* transmission problems
- communications session 4, 21, 24, 63, 64, 124
 - basic steps 6, 109
 - clearing settings 64
 - ending 25, 43, 57
 - pasting during 22
 - preparing for 31, 33, 65-80
 - saving 14
 - starting 17, 32, 35
 - template document for 88
 - temporarily suspending 67
- compatibility 124
- Compatibility settings 10, 11, 30, 32, 38, 40, 65, 70, 105
- CompuServe iv, 9, 15
- computer, host *See* host computer
- computer, personal *See* communicating with personal computer
- computer terminal 3
- configuration of hardware 88
- connection 4, 10, 32, 70, 125
 - direct 5, 30, 32, 38, 39, 70, 71, 72, 102, 105
 - making a 18, 39, 41
 - over phone lines 39
 - static 89
 - setting 72
 - sounds 18, 32
 - temporarily suspending 67
 - terminating 25, 43
 - through modem *See* modem
 - with host computer 18, 21, 33, 65-80
 - with personal computer 18, 21, 33, 74
- Connection Port setting 10, 32, 70, 72
- connect time 4, 25, 125
- control characters 33, 70, 77, 125
- Control keys 95-99, 112-13, 125 *See also* Command key
 - terminal commands 65, 77
 - used in log-on 20, 33
- Control Panel 69, 125
- copying
 - documents and applications to other disks 47
 - MacTerminal data to other documents 42

- onto Clipboard 22, 43
- paragraphs 43
- selecting data to copy 22, 43
- tables 43, 62
- Copy and Paste commands 8, 22, 43, 62-63
- Copy Table command 43, 62, 80
- creating a MacTerminal document 8
- Currently Active setting 78
- cursor 8, 113, 125
- cursor keys, in full-screen applications 86, 96, 99, 125
- Cursor Shape setting 11, 66-67
- Cut command 8, 62, 126

D

- data cable 102, 103, 115-116
 - pin assignments 121
- DEC VT100 3, 11, 12, 24, 40, 65, 66, 67, 79
 - full-screen applications 86
 - Control key commands 20, 65
 - features not implemented 119
 - keyboard keys 83-84, 95-99
 - Status Lights 11, 65, 67
- delay 126
- Delay Between Chars setting 13, 37, 73-74, 86
- Delay Between Lines setting 13, 37, 73-74
- delete, using Backspace 20, 79
- deleting recorded data 21
- desk accessories 8, 53, 63, 122, 123, 126
 - cutting from and pasting into 22, 24, 36, 123
- Desk Accessories command 53
- Dial command 32, 81, 126
- DIALOG iv
- dialog box 126
- Dial Phone setting 31, 82
- dial tone 82
- dimmed menu commands and options 58, 63, 65, 66, 70, 81, 126
- direct connection *See* connection
- disk 127
 - changing disks 46
 - ejecting a disk 46, 56
 - hard disk *See* hard disk
 - space available on 47, 53, 64
- disk drives, saving on 46
- disk full message 14
- display *See also* screen display
 - area of terminal screen 8, 22, 37, 57, 64, 67, 113
 - problems with 40
- incoming data 65
 - problems with *See* transmission problems

- status line on IBM terminal 113-14
- with full screen host applications 86, 113
- document 9, 127
 - MacTerminal 7, 8, 9
 - opening 8
 - preset on program disk
 - Commercial Services 9
 - Hard Disk 9
 - Macintosh 9
 - size of, in relation to disk space 47
- Don't Record Lines Off Top command 21, 31, 63-64
- Dow Jones News/Retrieval iv, 9, 17
- drag 127
- dragging icons, to copy files 47
- Drive button, in dialog box 54, 56, 57
- duplex signal transmission 10 *See also* full duplex and half duplex

E

- echo 127
 - local *See* Local Echo setting
- echo back 19, 37
- Edit menu commands 62-63
- Eject button, in dialog box 54, 56, 57
- ejecting a disk 46, 56
- Empty Trash command 47
- emulating *See* IBM 3278 *and* DEC VT100
- emulator 128
- enable XOn/XOff 10
- ending a session *See* communications session
- Enter key 20, 95, 98, 112, 128
- equipment 5
- errors in transfer 15, 76
- Escape key 20, 112-13, 128
- escape sequence 128
- even parity 10, 70 *See also* parity
- Excel, copying tables to 80
- exiting MacTerminal 43
- External Disk drive port 73, 88

F

- features, setting 11
- File Menu 54
- files 128
 - application, sending 38
 - new document 22
 - on other disks 35
 - opening 23
 - system, sending 38
 - type 13, 57

- File Transfer 128 *See also* transfer methods
 - and types of files 57
 - command 22, 23, 34
 - Protocol 13, 14, 24, 32, 58, 76
 - settings 13, 14, 31, 34, 41, 73-74
 - when receiving from mainframe 42
- Finder 22, 45, 61, 128
 - new file in 42
- font 128
- foreign-language character sets 36, 78-79
- format 129
- formatting, retained in transfer 15
- full duplex 10, 68, 129
- full screen applications 86
- function keys 83-84, 86, 96-99, 110-11, 129

G

- G0 78
- G1 78
- gauge, showing progress of transfer 22, 35, 42, 57
- gender changer 102, 103
- Get Info file command 47
- Graphics character set 78
- grave key equivalent 20, 95

H

- Haeberli, Martin 53
- half duplex 10, 68, 129
- handshake 10, 129
- Handshake compatibility setting 30, 65, 70, 71
- Hang Up command 25, 43, 81
- hard disk 30, 73, 88, 129
 - connected to different ports 88
- Hard Disk document 8, 9, 30, 88
- Hard Disk 20 *See* Apple Hard Disk 20
- hardware setup 88
- Hayes Smartmodem 5, 87
- heirarchical filing system 35
- Hide Clipboard command 63
- Hide Tab Ruler command 80
- hookup *See specific device name(s)*
- host computer 3, 18, 19, 130
 - commands from 64, 65
 - communicating with 21, 33, 63, 75, 77
 - settings for 30, 65-80
 - logging off 25
 - logging on 18, 32, 33
 - using applications 24, 86

I
IBM 4, 11
 communicating with 30, 103, 116
 status line and symbols 113
 system and AppleLine connection 101-14
IBM 3278 3, 4, 11, 12, 67, 104, 109
 and transfer 15, 76
 emulating 9, 11, 34, 66, 76, 128
 screen display 113
 equivalent keys 20, 110-13
 function keys 83, 110-11
 Keyboard Equivalents Table 112
 programmable keys 97, 99, 110-12
 terminal emulation setting 66, 104
icon 130
 blank page 23
ImageWriter printer 44
incoming calls 18, 31, 58
incoming data
 display of 65, 69
 problems with *See* transmission problems
incoming files *See* receiving files
information services 9, 11
 communicating with 30, 71
 transferring files to and from 15, 34
initialize 130
insertion point 130
insert mode 33
intelligent modems 87

J, K
K *See* kilobytes
Kbd locked indicator 65, 68
keyboard, locked 65, 68
keyboard characters 36
Keyboard command 20
Keyboard Configuration command *See* Backspace key
Key Caps desk accessory 78 130
key click VT100 feature 119
key equivalents 20, 95-99, 110-13
Keypad 86, 99, 110
keypad layouts 83-84, 99
Keypad menu 68, 83-84, 99, 130
kilobytes, in relation to file size 47

L
line breaks 37, 74
 and Return characters 23, 69
 setting 14, 34

line feed 130
 in transfer 15, 69
Line Width setting 11, 66-67, 74
Lisa 2/5 or 2/10 iv
Local Echo setting 10, 11, 12, 30, 35, 36, 37, 57, 63, 68,
 129, 130
locked keyboard *See* keyboard, locked
logging on 6, 18, 19
 to a host computer 18, 31
log-off 25, 109, 131
log-on 20, 33, 109, 131
lowercase letters 110

M
MacBinary transfer method 15, 18, 24, 32, 34, 76
Macintosh iv, v, 5, 30
Macintosh document 9, 30, 76
Macintosh file 13, 57
 transferring 15, 38, 76
Macintosh keyboard 20, 95-99, 110-13
Macintosh Plus iv, 35
 keyboard 95-99
Macintosh XL iv, 3, 5, 30, 38
MacTerminal 3, 107
 commands 52-85
 program and current session information 53
 quitting 43
 starting 7
 using with a hard disk 88
MacTerminal 1.1 transfer method 9, 15, 24, 30, 34, 38, 76
MacTerminal document 6, 8, 32, 35, 40, 109
 closing 55, 61
 opening 45
 preset documents 30
 setting up 30
MacWorks XL iv, 3
MacWrite
 and ASCII files 13
 line breaks 23, 75
mainframe 4, 131
 applications 22
 communicating with 30, 65-80, 103, 116
 multilingual *See* Character Sets command
 receiving files from 42, 64, 75
 screen display 113
 transferring files to 15
margin bell VT100 feature 119
mark parity 71
MCI Mail iv, 30, 40
 and handshake 71

menu bar 8, 131
menu commands, using 7, 8, 52-85
Mixed phone setting 16, 31, 82
mode 131
modem 4, 5, 31, 40, 58, 70, 72, 81, 103, 131
 See also Apple Modem
 attaching to Printer port 8, 38, 70, 100, 102
 answering the phone 87
 compatibility 87
 connecting 102-06, 116
 during transmission 18
 giving commands to 87
 resetting after being turned off 87
Modem phone setting 16, 31, 83
Modem port 30, 38, 70, 72-73, 102, 115
 hard disk connected to 88, 102, 115
Mode settings 11, 66

N

naming documents 55, 64
 incoming file 58
 untitled 45
 saving with different name 55
networks 40
New file command 54
New Line key equivalent 85
New Line setting 11, 12, 30, 36, 37, 69
No Carrier message *See* carrier
nonprinting characters setting 11
Note Pad 22, 24, 36, 53, 131
null parity *See* parity
Number of Rings Before Answer setting 31, 83
numeric keypad 83-85, 99, 131

O

odd parity 10, 70 *See also* parity
off-line 67, 132
OK button 30
on-line 132
On Line setting 11, 67
open 132
 MacTerminal document 45
 existing 45
 new 8, 30, 32
 received file 23
 text file 23
Open command 7, 8, 23, 45, 54
Option key 64, 78, 85, 86, 95, 97, 99, 111, 132
options *See* Settings menu
Orientation, of printed document *See* Page Setup command

P

Page Setup command 44, 59-60
paper feed, for printing *See* Print Selection command
paper settings, for printing *See* Page Setup command
paragraphs and Return characters 23, 75
parallel 132
parameters 132 *See also* communications parameters
parity 10, 71, 132
 errors 71
Parity setting 30, 70, 71
password 19, 106
Paste command 8, 22, 63, 132
 sending with 22, 24, 37, 38
 transfer protocol 39
pasting
 selections from terminal screen 22
 received data into an application document 43
Pasting Text setting 13, 73-74
personal computer *See* communicating with *and* connection
PF keys 84-85, 111
Phone menu 16, 18, 31, 81
phone network 33
phone number *See* access number
phone operation and modems 87
Phone port *See* Modem port
Phone Settings 16, 18, 31, 32, 82, 106
phone system setting 16
pin assignments for Apple Modem data cable 121
pin-plug connector 102, 115
pin-socket connector 102, 115
ports 72-73, 133
preset options 30, 66-83
primary character set 78
Printer port 115
 hard disk connected to 88
 modem connected to 8, 38, 72-73, 100
printing received data 44
print quality *See* Print Selection command
Print Selection command 44, 61, 133
print settings *See* Page Setup command
problems in transmission *See* transmission problems
prompt, of host computer 19, 33, 133
protocol 133 *See also* transfer methods
Protocol Conv setting 11, 67
Pulse phone setting 16, 31, 82

Q

Quit command 43, 61
quitting MacTerminal 43, 45, 61

R

Receive button in dialog box 58
Receive File command 15, 18, 32, 58, 133
receiving and saving information 14, 58, 64
receiving and sending
 conventions 14
 problems *See* transmission problems
receiving files 15, 39, 42, 58, 64, 70, 71, 76
recording 64
 a session 21
 data and saving 56
 screen information 22
Record Lines Off Top command 14, 21, 22, 31, 42, 63-64, 75, 133
rectangular boxes in incoming data *See* transmission problems
regular characters 36
remote computer
 role in communications network 40
 sending to 36
 settings 11, 65-80
remote diagnostic text mode VT100 feature 119
Repeat Ctrls setting 11, 69, 70
Reset command 21, 64
Retain Line Breaks setting 13, 14, 23, 73, 75
Return
 character 75
 in answerback message 77
 in transfer 15, 69
 restoring in text files 23
 key 97, 99
 equivalent 85
 repeat setting 70

S

Save command 46, 55, 133
Save As command 13, 31, 46, 55
Save Screens Before Clearing setting 13, 14, 22, 31, 42, 64, 73, 75
saving
 communications parameters 8, 40
 communications sessions 14, 31, 64
 communications settings 17, 31, 40
 documents *See* saving files
 document settings 46, 55
 files 14, 46, 55, 64
 before quitting 45
 on different disk 46
 previously untitled 56
 to application disk 42

 with new name 55
incoming data 31, 64
 as it scrolls off screen 42
incoming documents 23
 Return characters 15
Saving Lines Off Top settings 73, 75
screen display 22, 57, 64, 113 *See also* display
scroll area 134
scroll bars 8, 42, 67, 75, 134
scrolling 65, 67, 75, 133
 smooth scroll VT100 feature 119
security 19
Select All command 43, 63
selecting 134
 all data in document 43, 63
 data to print 44
 documents in Finder 47
 part of a document 43
 screen data 22
 turning off selection 63
Send button 35
Send File command 24, 39, 56
sending 134
 and receiving data 33, 65, 70, 73, 76
 conventions 14
 problems *See* transmission problems
 small amounts of text 36, 63
 errors 15, 76
 files 24, 31, 34, 39, 57
 by typing 39
 to Macintosh computer 34, 76
 stop sending 35
 tables of figures 34
 text files 74
Sending Text settings 13, 14, 73-74
send mode 33
serial transmission 134
setting features, of terminal 11
Settings menu 20, 22, 30, 38, 65-80
setting up MacTerminal document 30
Show Clipboard command 63
Show Tab Ruler/Hide Tab Ruler command 80
SOURCE, THE iv, 9
space parity 71
special keys 20
speed, of transmission 14, 37, 38 *See also* baud rate
starting a session 17, 32, 35, 135
start or stop bit *See* bits per character
Start Scrolling command 65, 71
static on phone lines 89

Status Information Area, of IBM terminal display 113
Status Lights setting 11, 65, 68, 135
status line 113
stop bit *See* bits per character
stopping a transmission *See* communications session
Stop Scrolling command 65, 71
Straight XModem transfer method 15, 18, 24, 32, 34, 57, 76
See also transfer methods
supervisor program *See* AppleLine supervisor program
switching drives *See* Drive button
SYLK files 13, 76
system file 135
 sending 38
System Folder 7

T

tab
 characters
 in tables 43, 62
 marker 135
 ruler 80, 135
Tab key repeat setting 70
tables, copying 43, 62
Telenet 33
telephone number *See* access number
telex iv
template document for communication session 88
temporary files 64
terminal 3, 135
 controls 110
 display area *See* screen display
 emulation 3, 11, 40, 135
 identifier 33
 keyboard 83-85
 screen display *See* screen display
 selecting data 22
 setting features 11, 65-80
 settings 11, 30, 66-70
 type 11, 12, 30, 40, 65, 66, 104, 107
 advantages 24
Terminal command 11, 66, 104
Terminal settings 38, 66, 104, 117
terminating a session *See* communications session
 and connection
text files 13, 35, 57, 135
 opening 23
 sending 74, 76
Text transfer method 15, 22, 24, 34, 35, 57, 76
See also transfer methods

THE SOURCE iv, 9
tilde, key equivalent 20, 95
Tone phone setting 16, 31, 82
transfer 136 *See also* sending *and* communications session
 methods 15, 24, 58, 73, 76
 and transfer screen display 22
 and types of files 57, 76
 progress gauge 22, 35
transmission *See also* sending *and* communications session
 preparing for 13, 65-80
 problems 89
transmit 136
Transparent setting 70
Trash icon 47
troubleshooting 89-90
TTY 3, 11, 12, 40, 66, 70, 83, 136
Tymnet 33

U

Underline cursor shape setting 66-67
Undo command 8, 62
Unlock Keyboard command 65, 68
uppercase letters 110
U.S. ASCII character set 78
U.S. Robotics Auto Link 212A 5, 87

V

VAX computer 11
viewing
 additional lines of IBM 3278 data 113
 data wider than screen 8, 67
 previous screens of data 8, 75
 transferred files 22-3
VT52 mode setting 66
VT100 *See* DEC VT100

W

Wait for Call command 18, 32, 58, 76, 81
Western Union Easylink iv
width, of printed document 44 *See also* Page Setup command
window 136
Word Wrap Outgoing Text 34, 37, 73
Word Wrap setting 14

X, Y, Z

XModem Text transfer method 15, 18, 24, 32, 34, 35, 57, 76,
 136 *See also* transfer methods
XModem transfer protocol *See* Straight XModem transfer
 method
XOn/XOff 10, 30, 65, 70, 71, 129, 136

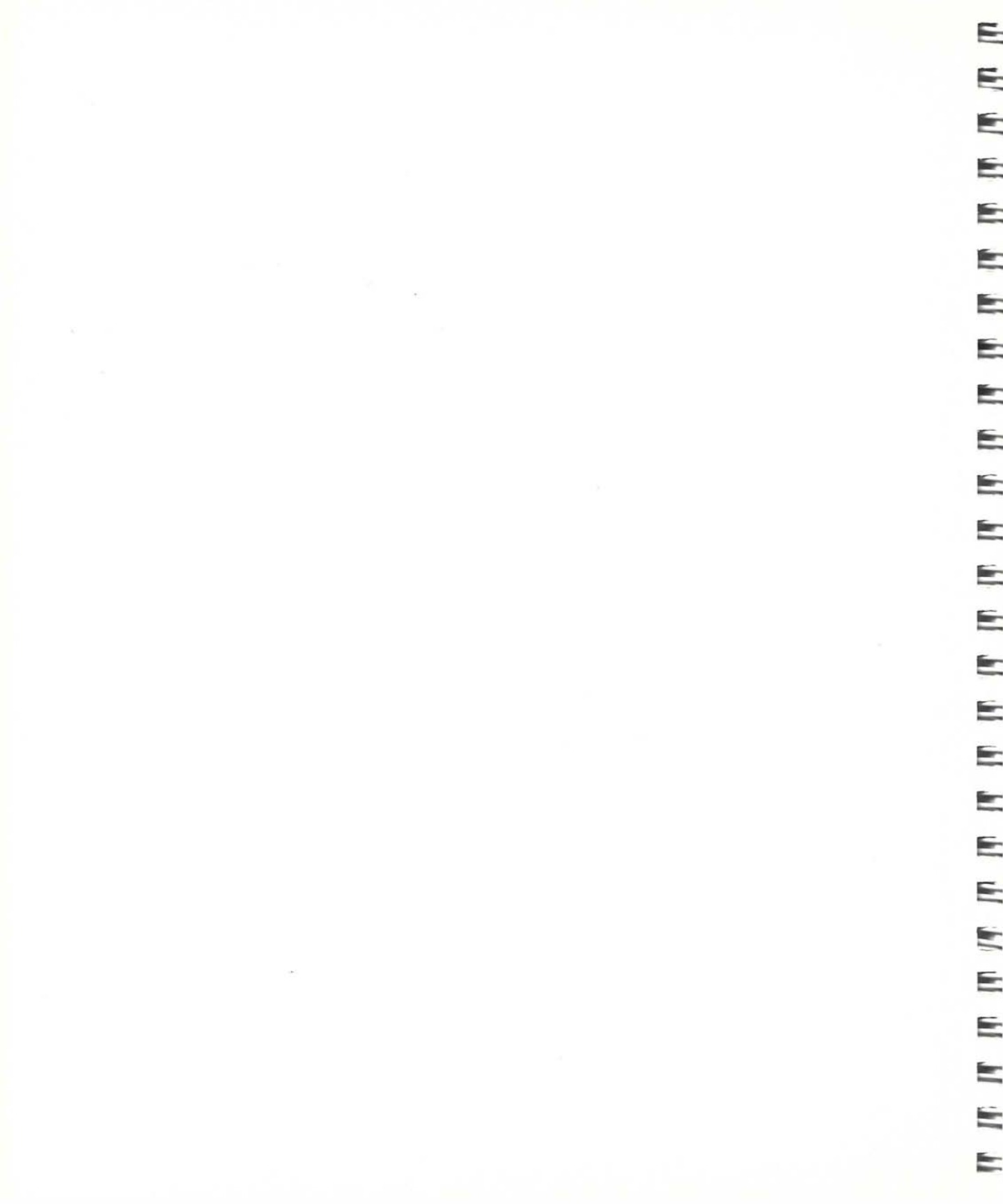

 **Tell Apple About**

Place
First Class
Postage
Here

■ Please contact your authorized Apple dealer when you have trained by Apple Computer and are given the resources to help you need the name of an authorized Apple dealer in your area.

■ Would you like to tell Apple what you think about this product we would like to hear from you. You can help us to questionnaire below and marking the appropriate boxes on it. If you have more than one response to a question, mark all the boxes. Thank you to Apple. Include additional pages of comments if you wish.

1. What is your overall satisfaction with MacTerminal? (**1**=poor, **2**=fair, **3**=good, **4**=very good)
2. How long have you used MacTerminal? (**1**=less than 1 month, **2**=1-3 months, **3**=3-6 months, **4**=6-12 months, **5**=more than 12 months)
3. Where did you purchase MacTerminal? (**1**=dealer, **2**=software store, **3**=mail order, **4**=other)
4. What computer are you using with MacTerminal? (**1**=Macintosh, **2**=Macintosh Plus, **3**=Macintosh SE, **4**=Macintosh XL, **5**=other)
5. What modem are you using? (**1**=300/1200 Apple Modem, **2**=other)
6. Where is MacTerminal used most often? (**1**=home, **2**=work, **3**=other)
7. What other computer system(s) do you contact with MacTerminal? (**1**=Apple computer, **2**=company mainframe, **3**=bulletin board system, **4**=other)
8. How easy is MacTerminal to use? (**1**=difficult . . . **6**=very easy)
9. How did you learn to use MacTerminal? (**1**=MacTerminal manual, **2**=Apple training, **3**=other)
10. Does MacTerminal meet your expectations? (**1**=no, **2**=yes)
11. What file transfer method do you use most often? (**1**=Text, **2**=Binary, **3**=MacTerminal 1.1, **4**=Straight XModem)
12. What protocols would you like to see supported in future versions? (**1**=MNP, **2**=other)
13. How would you rate your satisfaction with the MacTerminal manual? (**1**=poor, **2**=fair, **3**=good, **4**=very good)
14. How easy was the MacTerminal manual to read and understand? (**1**=difficult, **2**=fair, **3**=good, **4**=very easy)
15. Was the MacTerminal manual organized in a logical format? (**1**=no, **2**=yes)
16. How easy was it to find the information you needed? (**1**=difficult, **2**=fair, **3**=good, **4**=very easy)
17. Were the illustrations useful? (**1**=no, **2**=yes)
18. Which topics, if any, were confusing to you?
19. Please describe any errors or inconsistencies you may have noticed. (If you use numbers, they are helpful.)
20. What suggestions do you have for improving MacTerminal?

Thanks for your time and effort.

Return Address: _____

Apple Computer, Inc.
P.O. Box 1143
Cupertino, CA 95014
USA

Tell Apple About

- Please contact your authorized Apple dealer when you have questions about your Apple products. Dealers are trained by Apple Computer and are given the resources to handle service and support for all Apple products. If you need the name of an authorized Apple dealer in your area, call toll-free: 800-538-9696.
 - Would you like to tell Apple what you think about this product? After you have had an opportunity to use this product we would like to hear from you. You can help us to improve our products by responding to the questionnaire below and marking the appropriate boxes on the card at the right with a #2 lead pencil. If you have more than one response to a question, mark all the boxes that apply. Please detach the card and mail it to Apple. Include additional pages of comments if you wish.
1. What is your overall satisfaction with MacTerminal? (1=poor . . . 6=excellent)
 2. How long have you used MacTerminal? (1=less than 1 month, 2=2-6 months, 3=over 6 months)
 3. Where did you purchase MacTerminal? (1=dealer, 2=software store, 3=department store, 4=other)
 4. What computer are you using with MacTerminal? (1=Macintosh 128K, 2=Macintosh 512K, 3=Macintosh Plus, 4=Macintosh XL, 5=other)
 5. What modem are you using? (1=300/1200 Apple Modem, 2=Apple Personal Modem, 3=other)
 6. Where is MacTerminal used most often? (1=home, 2=work, 3=school, 4=other)
 7. What other computer system(s) do you contact with MacTerminal? (1=information services, 2=company mini-computer, 3=company mainframe, 4=bulletin board systems, 5=electronic mail systems)
 8. How easy is MacTerminal to use? (1=difficult . . . 6=very easy)
 9. How did you learn to use MacTerminal? (1=MacTerminal manual, 2=training class, 3=friend, 4=other)
 10. Does MacTerminal meet your expectations? (1=no, 2=yes)
 11. What file transfer method do you use most often? (1=Text, 2=MacBinary, 3=XModem Text, 4=MacTerminal 1.1, 5=Straight XModem)
 12. What protocols would you like to see supported in future versions of MacTerminal? (1=Kermit, 2=X.PC, 3=MNP)
 13. How would you rate your satisfaction with the MacTerminal manual? (1=poor . . . 6=excellent)
 14. How easy was the MacTerminal manual to read and understand? (1=difficult . . . 6=very easy)
 15. Was the MacTerminal manual organized in a logical format? (1=no, 2=yes)
 16. How easy was it to find the information you needed? (1=difficult . . . 6=very easy)
 17. Were the illustrations useful? (1=no, 2=yes)
 18. Which topics, if any, were confusing to you?
 19. Please describe any errors or inconsistencies you may have encountered with the MacTerminal manual. (Page numbers are helpful.)
 20. What suggestions do you have for improving MacTerminal?

Thanks for your time and effort.

030-1369-A

when you have questions about your Apple products. Dealers are resources to handle service and support for all Apple products. If dealer in your area, call toll-free: 800-538-9696.

about this product? After you have had an opportunity to use this you can help us to improve our products by responding to the appropriate boxes on the card at the right with a #2 lead pencil. If you mark all the boxes that apply. Please detach the card and mail it to us if you wish.

MacTerminal? (1=poor . . . 6=excellent)

How long? (1=less than 1 month, 2=2-6 months, 3=over 6 months)

Where? (1=dealer, 2=software store, 3=department store, 4=other)

Model? (1=Macintosh 128K, 2=Macintosh 512K, 3=Macintosh Plus,

4=Macintosh SE, 5=Apple Modem, 2=Apple Personal Modem, 3=other)

Where used? (1=home, 2=work, 3=school, 4=other)

How did you contact with MacTerminal?(1=information services, 2=company mini-computer, 3=retail board systems, 5=electronic mail systems)

How difficult? (1=difficult . . . 6=very easy)

How did you learn? (1=MacTerminal manual, 2=training class, 3=friend, 4=other)

Did you? (1=no, 2=yes)

How often? (1=Text, 2=MacBinary, 3=XModem Text,

4=AppleLink, 5=other) Will you be interested in future versions of MacTerminal? (1=Kermit, 2=X.PC,

3=other) How would you rate the MacTerminal manual? (1=poor . . . 6=excellent)

How easy to read and understand? (1=difficult . . . 6=very easy)

How well organized? (1=no, 2=yes)

How easy to use? (1=difficult . . . 6=very easy)

Other

What problems you may have encountered with the MacTerminal manual. (Page

Number) How useful was MacTerminal?

Grid of 20 rows and 12 columns of boxes for marking responses.

Please Do Not Mark Above This Line

1. [1] [2] [3] [4] [5] [6]

2. [1] [2] [3]

3. [1] [2] [3] [4]

4. [1] [2] [3] [4] [5]

5. [1] [2] [3]

6. [1] [2] [3] [4]

7. [1] [2] [3] [4] [5]

8. [1] [2] [3] [4] [5] [6]

9. [1] [2] [3] [4]

10. [1] [2]

11. [1] [2] [3] [4] [5]

12. [1] [2] [3]

13. [1] [2] [3] [4] [5] [6]

14. [1] [2] [3] [4] [5] [6]

15. [1] [2]

16. [1] [2] [3] [4] [5] [6]

17. [1] [2]

18. _____

19. _____

20. _____

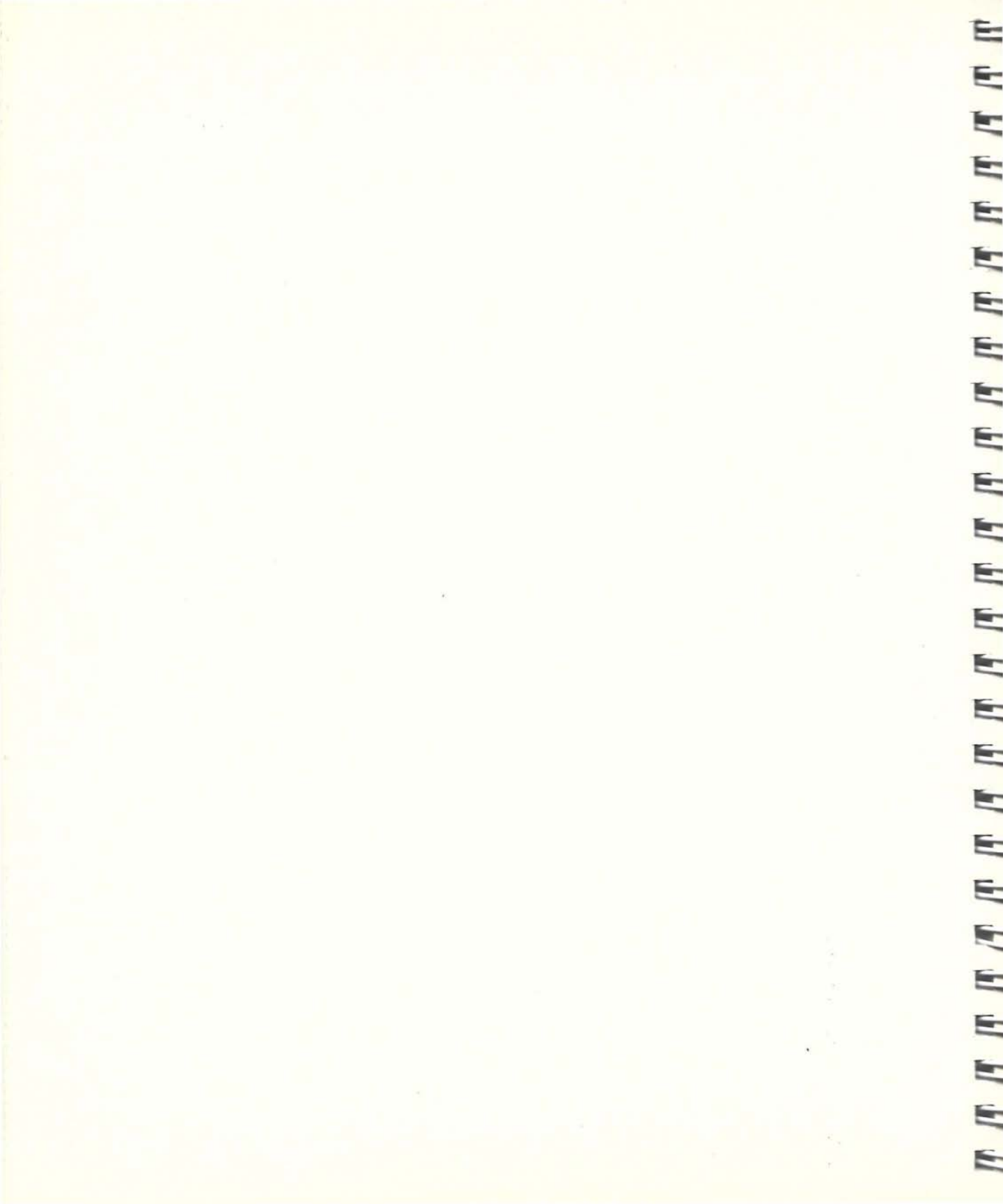

Limited Wa
on Media a
Replaceme

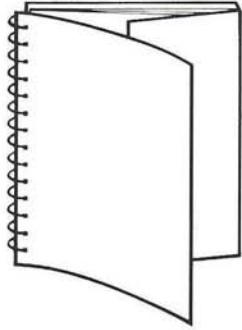

This book's binding lets it lie flat while you're working with your Macintosh. When you're using the book, keep the wraparound endflap tucked inside the back cover. To make it easy to spot the title when the book's on a shelf, fold the flap inside the front cover and set the book on the shelf with the title visible.



Macintosh™

MacTerminal™

Limited Warranty on Media and Replacement

If you discover physical defects in the manuals distributed with an Apple product or in the media on which a software product is distributed, Apple will replace the media or manuals at no charge to you, provided you return the item to be replaced with proof of purchase to Apple or an authorized Apple dealer during the 90-day period after you purchased the software. In addition, Apple will replace damaged software media and manuals for as long as the software product is included in Apple's Media Exchange Program. While not an upgrade or update method, this program offers additional protection for up to two years or more from the date of your original purchase. See your authorized Apple dealer for program coverage and details. In some countries the replacement period may be different; check with your authorized Apple dealer.

ALL IMPLIED WARRANTIES ON THE MEDIA AND MANUALS, INCLUDING IMPLIED WARRANTIES OF MERCHANTABILITY AND FITNESS FOR A PARTICULAR PURPOSE, ARE LIMITED IN DURATION TO NINETY (90) DAYS FROM THE DATE OF THE ORIGINAL RETAIL PURCHASE OF THIS PRODUCT.

Even though Apple has tested the software and reviewed the documentation, **APPLE MAKES NO WARRANTY OR REPRESENTATION, EITHER EXPRESS OR IMPLIED, WITH RESPECT TO SOFTWARE, ITS QUALITY, PERFORMANCE, MERCHANTABILITY, OR FITNESS FOR A PARTICULAR PURPOSE. AS A RESULT, THIS SOFTWARE IS SOLD "AS IS," AND YOU THE PURCHASER ARE ASSUMING THE ENTIRE RISK AS TO ITS QUALITY AND PERFORMANCE.**

IN NO EVENT WILL APPLE BE LIABLE FOR DIRECT, INDIRECT, SPECIAL, INCIDENTAL, OR CONSEQUENTIAL DAMAGES RESULTING FROM ANY DEFECT IN THE SOFTWARE OR ITS DOCUMENTATION, even if advised of the possibility of such damages. In particular, Apple shall have no liability for any programs or data stored in or used with Apple products, including the costs of recovering such programs or data.

THE WARRANTY AND REMEDIES SET FORTH ABOVE ARE EXCLUSIVE AND IN LIEU OF ALL OTHERS, ORAL OR WRITTEN, EXPRESS OR IMPLIED. No Apple dealer, agent, or employee is authorized to make any modification, extension, or addition to this warranty.

Some states do not allow the exclusion or limitation of implied warranties or liability for incidental or consequential damages, so the above limitation or exclusion may not apply to you. This warranty gives you specific legal rights, and you may also have other rights which vary from state to state.



Apple Computer, Inc.
20525 Mariani Avenue
Cupertino, California 95014
408-996-1010
TLX 171-576

030-1179-B
Printed in U.S.A.

